



[DBPR HOME](#) | [ABOUT DBPR](#) | [DBPR DIVISIONS](#) | [CONTACT DBPR](#)

[BCIS Home](#) | [Log In](#) | [User Registration](#) | [Hot Topics](#) | [Submit Surcharge](#) | [Stats & Facts](#) | [Publications](#) | [Contact Us](#) | [BCIS Site Map](#) | [Links](#) | [Search](#)



Product Approval
USER: Public User

[Product Approval Menu](#) > **Application Detail**

OFFICE OF THE SECRETARY

FL #	FL31134-R2								
Application Type	Revision								
Code Version	2023								
Application Status	Approved								
Comments									
Archived	<input type="checkbox"/>								
Product Manufacturer	Sunshine Windows Manufacturing Inc.								
Address/Phone/Email	1745 West 33rd Place Hialeah, FL 33012 (305) 364-9952 Ext 109 noel_m_2001@yahoo.com								
Authorized Signature	Jalal Farooq veronica@afceng.com								
Technical Representative									
Address/Phone/Email									
Quality Assurance Representative									
Address/Phone/Email									
Category	Windows								
Subcategory	Fixed								
Compliance Method	Evaluation Report from a Florida Registered Architect or a Licensed Florida Professional Engineer <input type="checkbox"/> Evaluation Report - Hardcopy Received								
Florida Engineer or Architect Name who developed the Evaluation Report	Jalal Farooq								
Florida License	PE-81223								
Quality Assurance Entity	Keystone Certifications, Inc.								
Quality Assurance Contract Expiration Date	02/28/2029								
Validated By	Abel Carrasco, PE <input checked="" type="checkbox"/> Validation Checklist - Hardcopy Received								
Certificate of Independence	FL31134 R2 COI SS - Certificate of Independence.pdf								
Referenced Standard and Year (of Standard)	<table border="0"> <thead> <tr> <th>Standard</th> <th>Year</th> </tr> </thead> <tbody> <tr> <td>TAS 201</td> <td>1994</td> </tr> <tr> <td>TAS 202</td> <td>1994</td> </tr> <tr> <td>TAS 203</td> <td>1994</td> </tr> </tbody> </table>	Standard	Year	TAS 201	1994	TAS 202	1994	TAS 203	1994
Standard	Year								
TAS 201	1994								
TAS 202	1994								
TAS 203	1994								
Equivalence of Product Standards Certified By									
Sections from the Code									

Product Approval Method

Method 1 Option D

Date Submitted

07/27/2023

Date Validated

07/27/2023

Date Pending FBC Approval

08/01/2023

Date Approved

10/18/2023

Summary of Products

FL #	Model, Number or Name	Description
31134.1	Series 4230 Aluminum Fixed Window	Large missile impact resistant aluminum fixed window.
Limits of Use Approved for use in HVHZ: Yes Approved for use outside HVHZ: Yes Impact Resistant: Yes Design Pressure: +90/-90 Other: See drawing 19-118F for span vs load combination and installation details.		Installation Instructions FL31134_R2_II_SS-4320_FW(LMI)-DWG_19-118F(2023).pdf Verified By: Jalal Farooq PE 81223 Created by Independent Third Party: Yes Evaluation Reports FL31134_R2_AE_SS-4230_FIXED(LMI)-PAE_2023.pdf Created by Independent Third Party: Yes
31134.2	Series 4230 Aluminum Fixed Window	Non-impact aluminum fixed window
Limits of Use Approved for use in HVHZ: Yes Approved for use outside HVHZ: Yes Impact Resistant: No Design Pressure: +100/-100 Other: See drawing 19-117F for span vs load combination and installation details		Installation Instructions FL31134_R2_II_SS-4320_FW(NI)-DWG_19-117F(2023).pdf Verified By: Jalal Farooq PE 81223 Created by Independent Third Party: Yes Evaluation Reports FL31134_R2_AE_SS-4230_FW(NI)-PAE_2023.pdf Created by Independent Third Party: Yes

[Back](#)

[Next](#)

Contact Us :: [2601 Blair Stone Road, Tallahassee FL 32399](#) Phone: 850-487-1824

The State of Florida is an AA/EEO employer. [Copyright 2007-2013 State of Florida.](#) :: [Privacy Statement](#) :: [Accessibility Statement](#) :: [Refund Statement](#)

Under Florida law, email addresses are public records. If you do not want your e-mail address released in response to a public-records request, do not send electronic mail to this entity. Instead, contact the office by phone or by traditional mail. If you have any questions, please contact 850.487.1395. *Pursuant to Section 455.275(1), Florida Statutes, effective October 1, 2012, licensees licensed under Chapter 455, F.S. must provide the Department with an email address if they have one. The emails provided may be used for official communication with the licensee. However email addresses are public record. If you do not wish to supply a personal address, please provide the Department with an email address which can be made available to the public. To determine if you are a licensee under Chapter 455, F.S., please click [here](#).



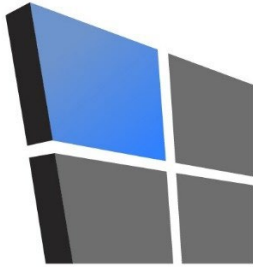

AL-FAROOQ CORPORATION

CONSULTING ENGINEERS & PRODUCT DEVELOPMENT

August 11, 2020

Product Approval Administrator
Building Codes & Standards Section
Department of Business & Professional Regulations
1940 North Monroe Street, Suite 90
Tallahassee, FL 32399-2100

To whom it may concern,

As the design engineer retained to prepare the product approval(s) associated with this letter as shown below on this same web page, I do hereby declare that I do not have and will not have any financial interest in any company manufacturing or distributing the referenced product(s), nor do I have or will have any financial interest with any other entity involved in the approval process of the referenced product(s).

Sincerely,



Sealed 8-11-2020

Jalal Farooq, P.E.
CFO

THESE WINDOWS ARE RATED FOR LARGE & SMALL MISSILE IMPACT. SHUTTERS ARE NOT REQUIRED.

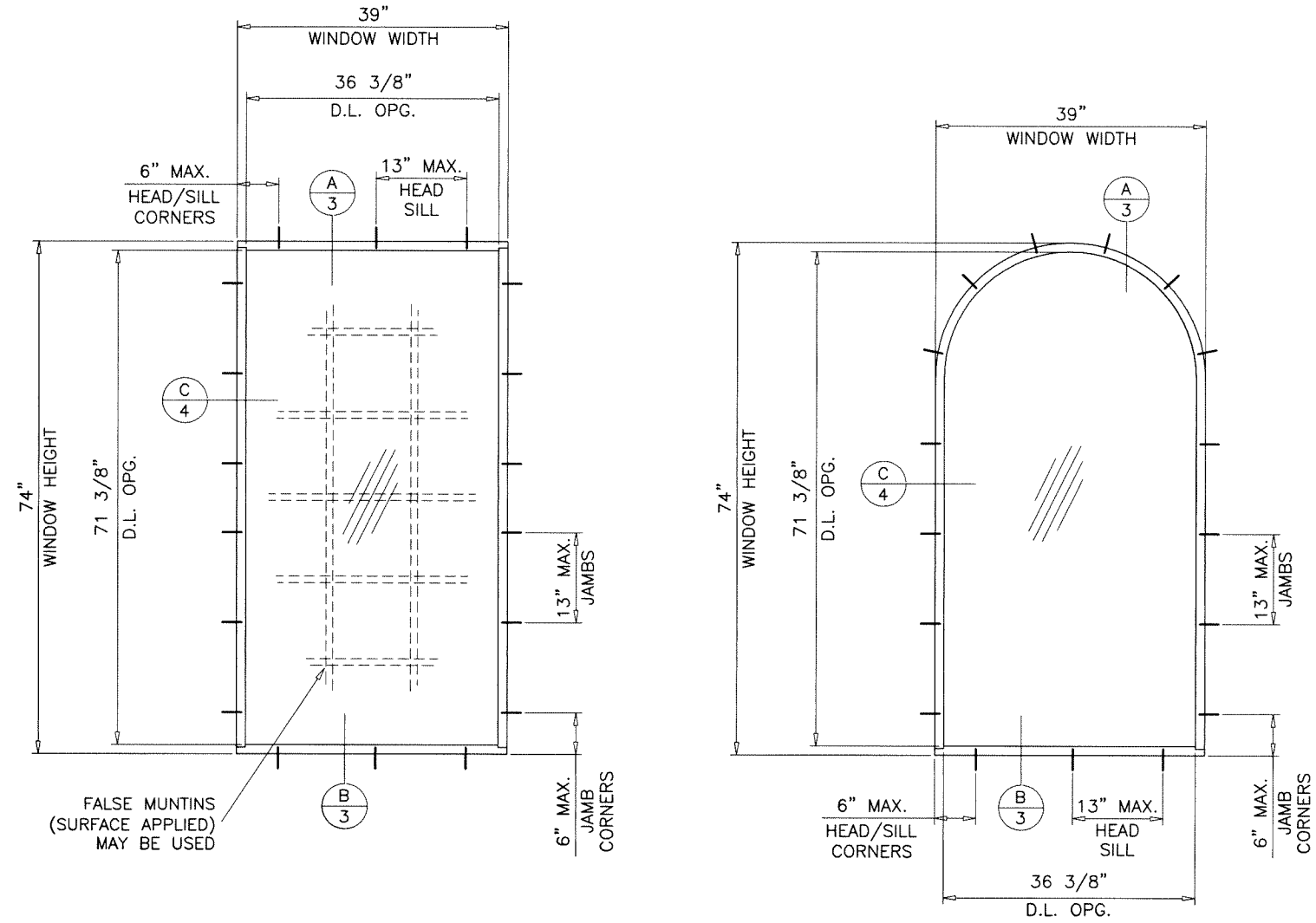

TYPICAL ELEVATIONS
(TESTED UNITS)

SERIES-4230
ALUMINUM FIXED WINDOW

DESIGN LOAD RATINGS FOR THESE WINDOWS TO BE AS PER CHARTS SHOWN ON SHEET 2.

APPROVAL APPLIES TO SINGLE UNITS OR SIDE BY SIDE COMBINATIONS OF FIX./FIX. OR FIXED WITH OTHER WINDOW TYPES IN MODULES OF TWO OR MORE WINDOWS USING F.B.C. APPROVED MULLIONS IN BETWEEN.

LOWER DESIGN PRESSURE FROM WINDOWS OR MULLION APPROVAL WILL APPLY TO ENTIRE SYSTEM.

THIS PRODUCT HAS BEEN DESIGNED AND TESTED TO COMPLY WITH THE REQUIREMENTS OF THE 2020 (7TH EDITION)/2023 (8TH EDITION) FLORIDA BUILDING CODE INCLUDING HIGH VELOCITY HURRICANE ZONE (HVHZ).

1BY OR 2BY WOOD BUCKS & BUCK FASTENERS BY OTHERS, MUST BE DESIGNED AND INSTALLED ADEQUATELY TO TRANSFER APPLIED PRODUCT LOADS TO THE BUILDING STRUCTURE.

ANCHORS SHALL BE CORROSION RESISTANT, SPACED AS SHOWN ON DETAILS AND INSTALLED PER MANUF'S INSTRUCTIONS. SPECIFIED EMBEDMENT TO BASE MATERIAL SHALL BE BEYOND WALL DRESSING OR STUCCO.

A LOAD DURATION INCREASE IS USED IN DESIGN OF ANCHORS INTO WOOD ONLY.

ALL SHIMS TO BE HIGH IMPACT, NON-METALLIC AND NON-COMPRESSIBLE.

MATERIALS INCLUDING BUT NOT LIMITED TO STEEL/METAL SCREWS, THAT COME INTO CONTACT WITH OTHER DISSIMILAR MATERIALS SHALL MEET THE REQUIREMENTS OF THE 2020/2023 FLORIDA BLDG. CODE & ADOPTED STANDARDS.

THIS PRODUCT APPROVAL IS GENERIC AND DOES NOT PROVIDE INFORMATION FOR A SITE SPECIFIC PROJECT, i.e. LIFE SAFETY OF THIS PRODUCT, ADEQUACY OF STRUCTURE RECEIVING THIS PRODUCT AND SEALING AROUND OPENING FOR WATER INFILTRATION RESISTANCE ETC. CONDITIONS NOT SHOWN IN THIS DRAWING ARE TO BE ANALYZED SEPARATELY, AND TO BE REVIEWED BY BUILDING OFFICIAL.

DESIGN LOADS SHOWN ARE BASED ON 'ALLOWABLE STRESS DESIGN (ASD)'.

MANUFACTURER'S LABEL SHALL BE LOCATED ON A READILY VISIBLE LOCATION IN ACCORDANCE WITH SECTION 1709.9.3 OF FLORIDA BUILDING CODE. LABELING TO COMPLY WITH SECTION 1709.9.2.

Sealed: 7/26/2023

FL #31134

- A- CONTRACTOR TO BE RESPONSIBLE FOR THE SELECTION, PURCHASE AND INSTALLATION OF THIS PRODUCT BASED ON THIS PRODUCT EVALUATION PROVIDED HE/SHE DOES NOT DEVIATE FROM THE CONDITIONS DETAILED ON THIS DOCUMENT.
- B- THIS PRODUCT EVALUATION DOCUMENT WILL BE CONSIDERED INVALID IF ALTERED BY ANY MEANS.
- C- SITE SPECIFIC PROJECTS SHALL BE PREPARED BY A FLORIDA REGISTERED ENGINEER OR ARCHITECT WHICH WILL BECOME THE ENGINEER OF RECORD (E.O.R.) FOR THE PROJECT AND WHO WILL BE RESPONSIBLE FOR THE PROPER USE OF THE P.E.D. ENGINEER OF RECORD, ACTING AS A DELEGATED ENGINEER TO THE P.E.D. ENGINEER SHALL SUBMIT TO THIS LATTER THE SITE SPECIFIC DRAWINGS FOR REVIEW.
- D- THIS P.E.D. SHALL BEAR THE DATE AND ORIGINAL SEAL AND SIGNATURE OF THE PROFESSIONAL ENGINEER OF RECORD THAT PREPARED IT.

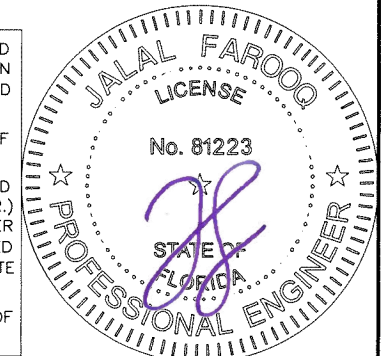

af c
AL-FAROOQ CORPORATION
ENGINEERS & PRODUCT DEVELOPMENT
9360 SUNSET DRIVE, SUITE 220
MIAMI, FLORIDA 33173 (C.A.N. 3538)
TEL. (305) 264-8100 FAX. (305) 262-6978
COMP-ANL \ 19-118F-SWM

SERIES-4230 ALUMINUM FIXED WDW. (L.M.I.)
Sunshine Windows Manufacturing, Inc.
1785 West 33rd Place
Hialeah, FL. 33012
Tel. (305) 364-9952 Fax. (305) 828-5118

no.	date	description	by
A	08.27.20	UPDATED TO 2020 FBC	
B	07.21.23	UPDATED TO 2023 FBC	

date: 11-06-19	scale: 1/2" = 1"	dr. by: TARIQ	chk. by:
drawing no. 19-118F			
sheet 1 of 5			

DESIGN LOAD CAPACITY - PSF			
FRAME DIMS.		5/16" LAM. GLASS	
WIDTH	HEIGHT	EXT.(+)	INT.(-)
19-1/8"	26"	90.0	90.0
26-1/2"		90.0	90.0
37"		90.0	90.0
53-1/8"		90.0	90.0
19-1/8"	38-3/8"	90.0	90.0
26-1/2"		90.0	90.0
37"		90.0	90.0
53-1/8"		90.0	90.0
19-1/8"	50-5/8"	90.0	90.0
26-1/2"		90.0	90.0
37"		90.0	90.0
53-1/8"		69.3	69.3
19-1/8"	56"	90.0	90.0
26-1/2"		90.0	90.0
37"		90.0	90.0
39"		90.0	90.0
19-1/8"	63"	90.0	90.0
26-1/2"		90.0	90.0
37"		90.0	90.0
39"		90.0	90.0
19-1/8"	72"	90.0	90.0
26-1/2"		90.0	90.0
37"		90.0	90.0
39"		90.0	90.0
19-1/8"	74"	90.0	90.0
26-1/2"		90.0	90.0
37"		90.0	90.0
39"		90.0	90.0
19-1/8"	76"	90.0	90.0
26-1/2"		90.0	90.0
37"		90.0	90.0

DESIGN LOAD CAPACITY - PSF				
FRAME DIMS.		5/16" LAM. GLASS		
WIDTH	HEIGHT	EXT.(+)	INT.(-)	
24"	24"	90.0	90.0	
30"		90.0	90.0	
36"		90.0	90.0	
42"		90.0	90.0	
48"		90.0	90.0	
54"		90.0	90.0	
60"		90.0	90.0	
66"		90.0	90.0	
72"		90.0	90.0	
78"		90.0	90.0	
84"		90.0	90.0	
90"		90.0	90.0	
96"	36"	90.0	90.0	
102"		90.0	90.0	
108"		90.0	90.0	
112"		90.0	90.0	
24"		48"	90.0	90.0
30"			90.0	90.0
36"			90.0	90.0
42"			90.0	90.0
48"			90.0	90.0
54"			90.0	90.0
60"			90.0	90.0
66"			90.0	90.0
72"	90.0		90.0	
78"	90.0		90.0	
24"	60"		90.0	90.0
30"			90.0	90.0
36"		90.0	90.0	
42"		83.6	83.6	
48"		73.1	73.1	
24"	72"	90.0	90.0	
30"		90.0	90.0	
36"		90.0	90.0	
24"		84"	90.0	90.0
30"			90.0	90.0
32"	90.0		90.0	
24"	108"	90.0	90.0	
43"		81.6	81.6	
46"		76.3	76.3	
48"		73.1	73.1	
53"		66.2	66.2	

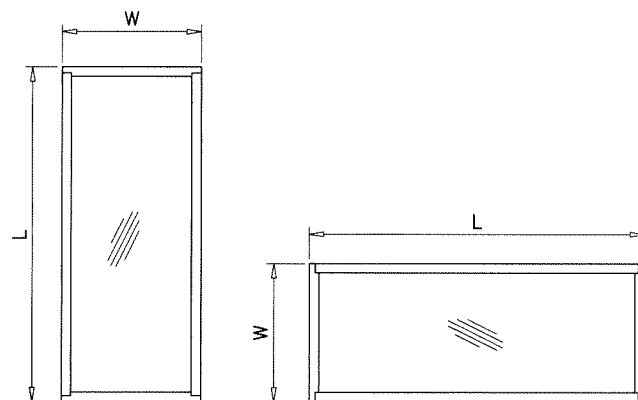
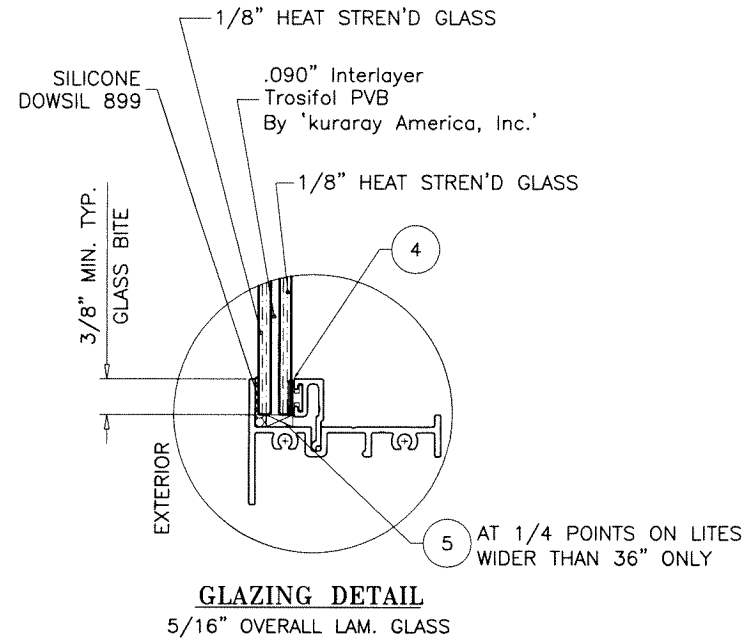

NOTE:
WIDTH AND LENGTH DIMENSIONS CAN BE
ORIENTED VERTICALLY OR HORIZONTALLY
AS SHOWN ABOVE.

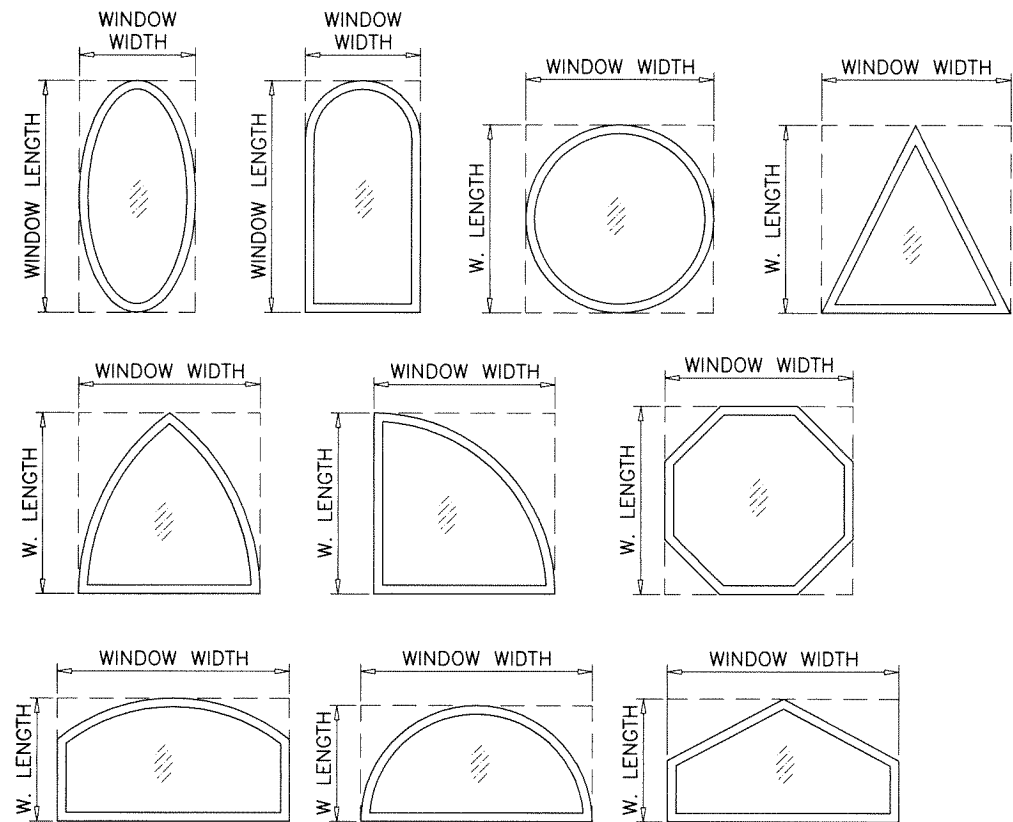

ALLOWABLE LOADS FOR ALTERNATE SHAPES AS SHOWN ABOVE OR SIMILAR CAN BE
VERIFIED BY INSCRIBING PICTURE WINDOW SHAPE WITHIN SQUARE OR RECTANGLE AS
SHOWN IN DOTTED LINES AND OBTAINING ALLOWABLE LOADS FROM THOSE SHAPES.

NOTE:
GLASS CAPACITIES ON THIS SHEET ARE
BASED ON ASTM E1300-09 (3 SEC. GUSTS).

Sealed: 7/26/2023

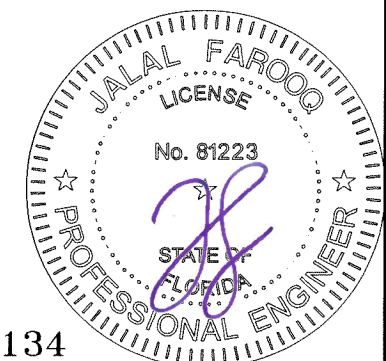

FL #31134

AL-FAROOQ CORPORATION
ENGINEERS & PRODUCT DEVELOPMENT
9360 SUNSET DRIVE, SUITE 220
MIAMI, FLORIDA 33173
TEL. (305) 264-8100 FAX. (305) 262-6978
COMP-ANL\19-118F-SWM

SERIES-4230 ALUMINUM FIXED WDW. (L.M.I.)
Sunshine Windows Manufacturing, Inc.
1785 West 33rd Place
Hialeah, FL. 33012
Tel. (305) 364-9952 Fax. (305) 828-5118

revisions:	no	date	by	description

date: 11-06-19	scale: -	dr. by: TARIQ	chk. by:
drawing no. 19-118F			
sheet 2 of 5			

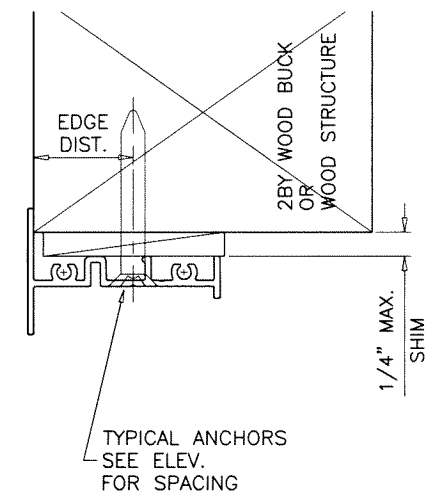
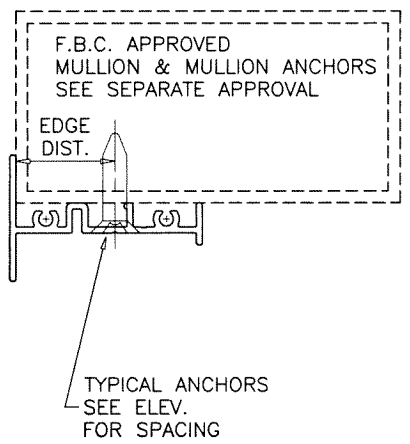
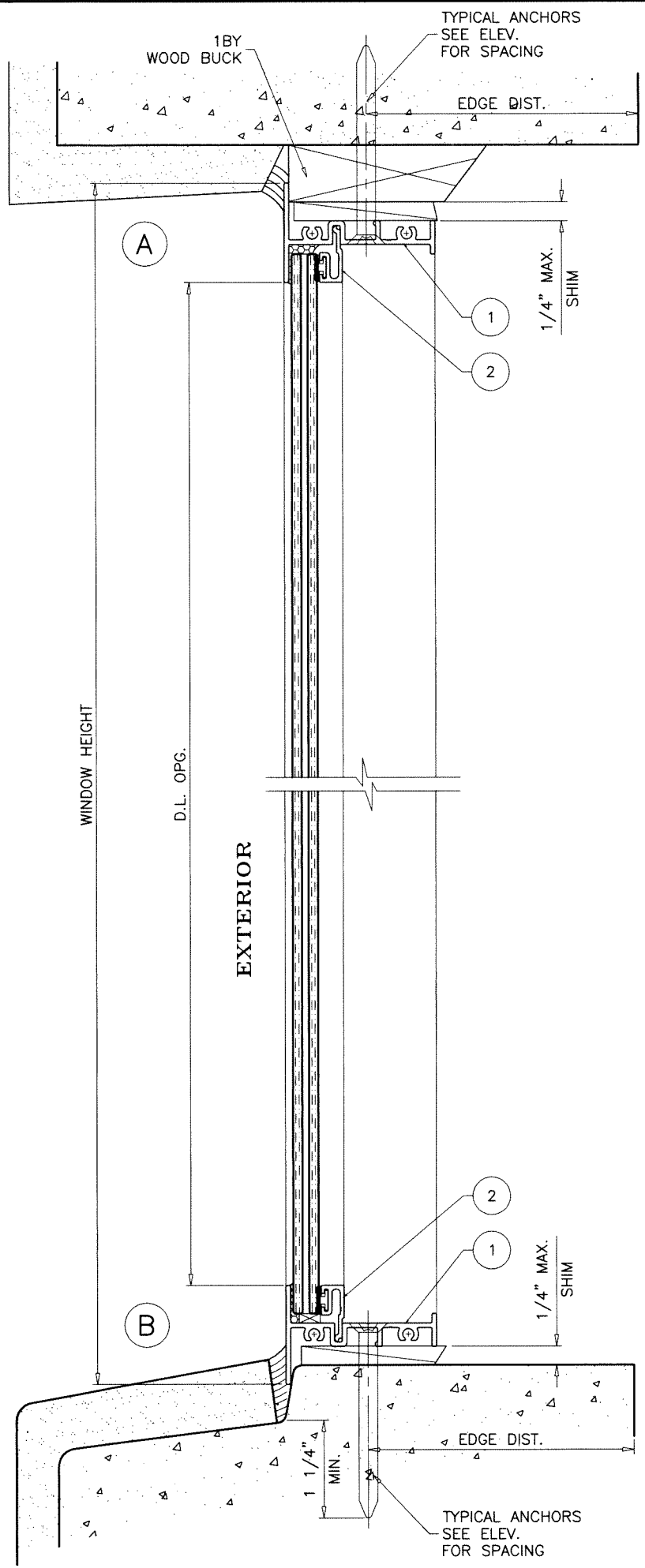

WOOD BUCKS AND METAL STRUCTURE NOT BY 'SUNSHINE WDWS.' MUST SUSTAIN LOADS IMPOSED BY GLAZING SYSTEM AND TRANSFER THEM TO THE BUILDING STRUCTURE.

TYPICAL ANCHORS: SEE ELEV. FOR SPACING
1/4" DIA. ULTRACON+ BY 'DEWALT' (Fu=164 KSI, Fy=148 KSI)
 INTO 2BY WOOD BUCKS OR WOOD STRUCTURES
 1-1/2" MIN. PENETRATION INTO WOOD (HEAD/SILL/JAMBS)
 THRU 1BY BUCKS INTO CONC. OR BLOCKS
 1-1/4" MIN. EMBED INTO CONCRETE (HEAD/SILL/JAMBS)
 1-1/4" MIN. EMBED INTO BLOCKS (JAMBS)
 DIRECTLY INTO CONCRETE OR BLOCKS
 1-1/4" MIN. EMBED INTO CONCRETE (HEAD/SILL/JAMBS)
 1-1/4" MIN. EMBED INTO BLOCKS (JAMBS)
#14 SMS OR SELF DRILLING SCREWS (GRADE 2 CRS)
 INTO F.B.C. APPROVED MULLIONS
 OR
 INTO METAL STRUCTURES (HEAD/SILL/JAMBS)
 (3) THREADS MIN. TO EXTEND BEYOND METAL THICKNESS
 ALUMINUM: 1/8" THK. MIN. (6063-T5 MIN.)
 STEEL: 1/8" THK. MIN. (Fy = 36 KSI MIN.)
 (STEEL IN CONTACT WITH ALUMINUM TO BE PLATED OR PAINTED)

TYPICAL EDGE DISTANCE
 INTO CONCRETE AND BLOCKS = 2-1/2" MIN.
 INTO WOOD STRUCTURE = 1" MIN.
 INTO METAL STRUCTURE = 3/4" MIN.
 WOOD AT HEAD, SILL OR JAMBS SG = 0.55 MIN.
 CONCRETE AT HEAD, SILL OR JAMBS f'c = 3000 PSI MIN.
 C-90 HOLLOW/FILLED BLOCK AT JAMBS f'm = 2000 PSI MIN.

Sealed: 7/26/2023



FL #31134

AL-FAROOQ CORPORATION
 ENGINEERS & PRODUCT DEVELOPMENT
 9360 SUNSET DRIVE, SUITE 220
 MIAMI, FLORIDA 33173
 TEL. (305) 264-8100 FAX. (305) 262-6978
 COMP-ANL\19-118F-SWM

SERIES-4230 ALUMINUM FIXED WDW. (L.M.I.)
Sunshine Windows Manufacturing, Inc.
 1785 West 33rd Place
 Hialeah, FL 33012
 Tel. (305) 364-9952 Fax. (305) 828-5118

revisions:		by description	
no	date		

date: 11-06-19
 scale: 1/2" = 1"
 dr. by: TARIQ
 chk. by:
 drawing no.
19-118F
 sheet 3 of 5

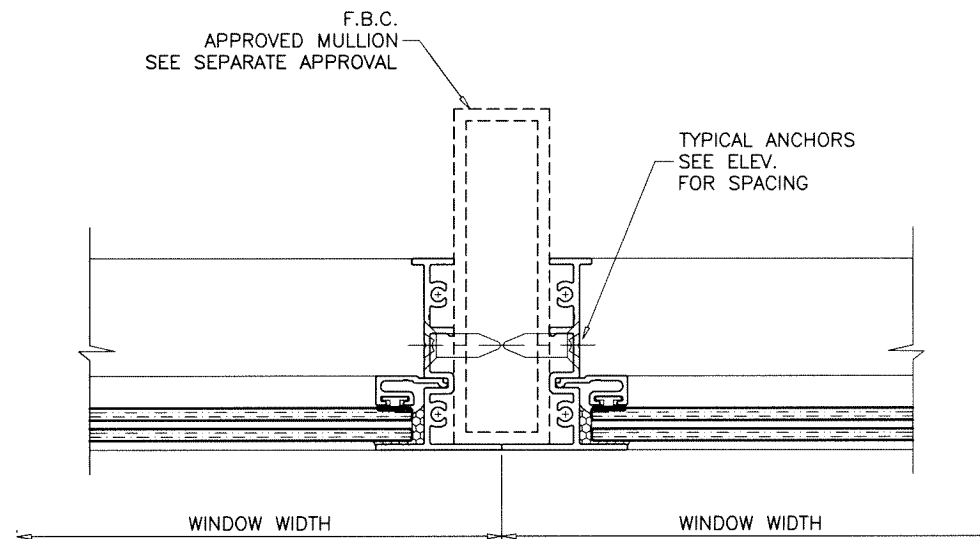
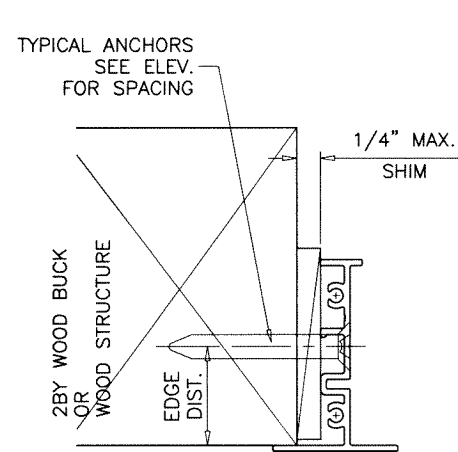
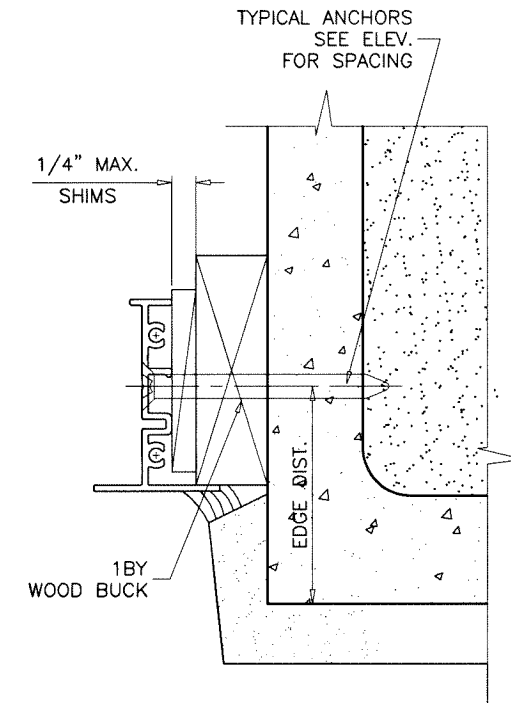
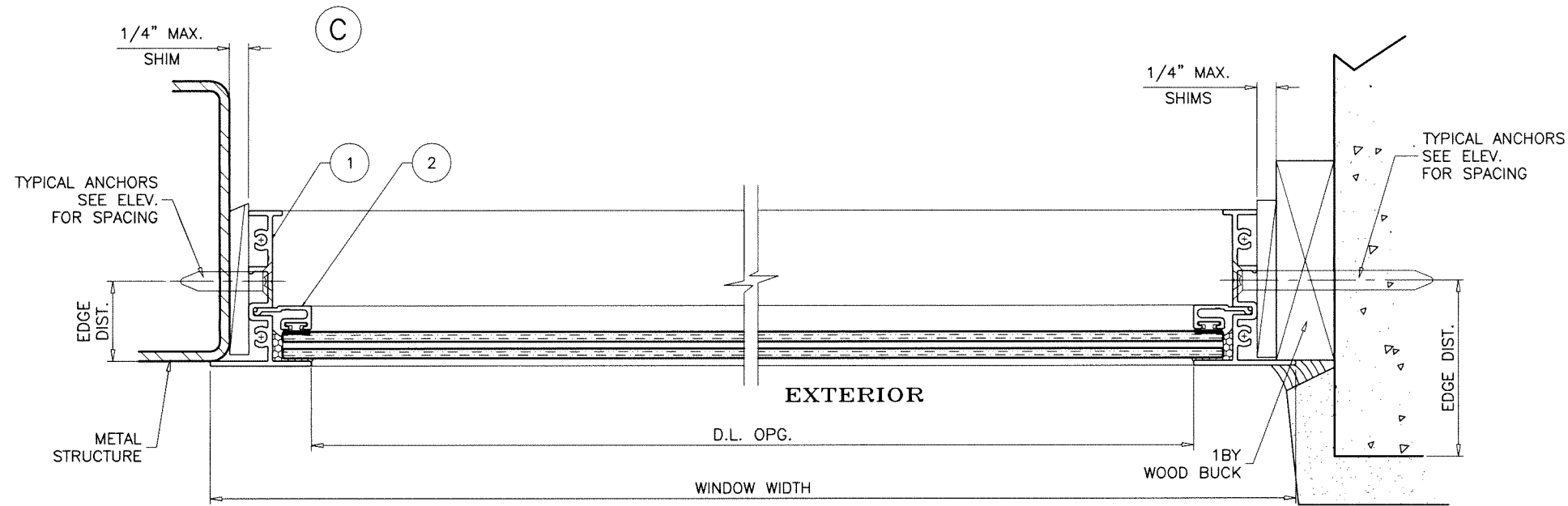

Sealed: 7/26/2023



FL #31134

af c
AL-FAROOQ CORPORATION
 ENGINEERS & PRODUCT DEVELOPMENT
 9360 SUNSET DRIVE, SUITE 220 (C.A.N. 3538)
 MIAMI, FLORIDA 33173 TEL. (305) 264-8100 FAX. (305) 262-6978
 COMP-ANL\19-118F-SWM

SERIES-4230 ALUMINUM FIXED WDW. (L.M.I.)
Sunshine Windows Manufacturing, Inc.
 1785 West 33rd Place
 Hialeah, FL. 33012
 Tel. (305) 364-9952 Fax. (305) 828-5118

revisions:	no	date	by	description

date: 11-06-19
 scale: 1/2" = 1"
 dr. by: TARIQ
 chk. by:
 drawing no.
19-118F
 sheet 4 of 5

ITEM	PART #	QUANTITY	DESCRIPTION	MATERIAL	MANF./SUPPLIER/REMARKS
1	SW-101	4	WINDOW FRAME	6063-T6	-
2	30684	4	GLAZING BEAD	6063-T6	-
4	SW-3082	AS REQD.	GLAZING BEAD BULB	TPV/ POLYPROPYLENE	MELTPOINT
5	SBEP2	AS REQD.	SETTING BLOCKS AT 1/4 POINTS (1/4" X 5/8")	EPDM	DUROMETER 80±5 SHORE A
6	#8 X 1"	AS REQD.	FRAME ASSEMBLY FASTENERS	CRS	P.H. SMS
7	BOSTIK 915	AS REQD.	EXTERIOR CORNER SEALANT	POLYURETHANE	-

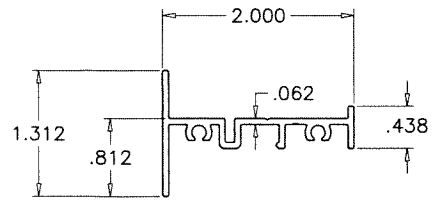

① WINDOW FRAME

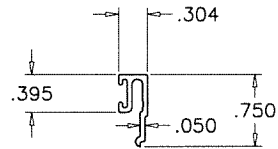

② GLZING BEAD

SEALANT:

ALL JOINTS AND FRAME CONNECTIONS SEALED WITH SCHNEE MOREHEAD SM-5504 JOINT SEALER.

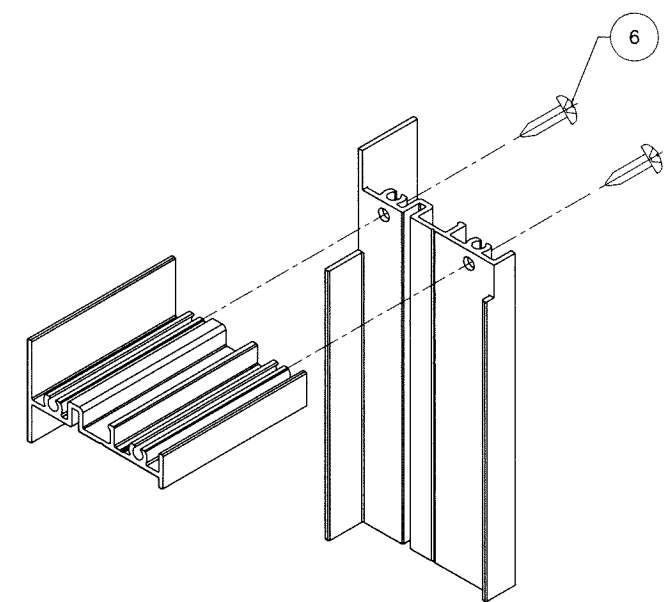

RECT. OR SQUARE WINDOWS

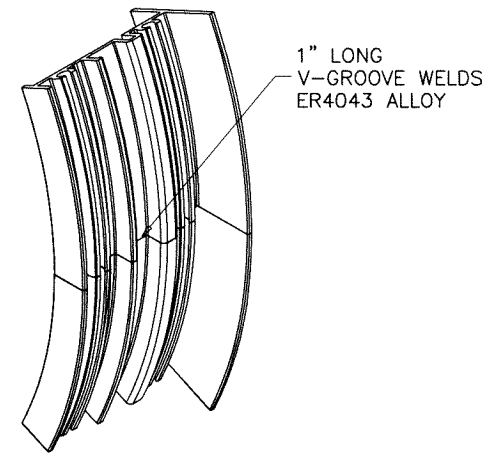

CIRCULAR WINDOWS

Sealed: 7/26/2023

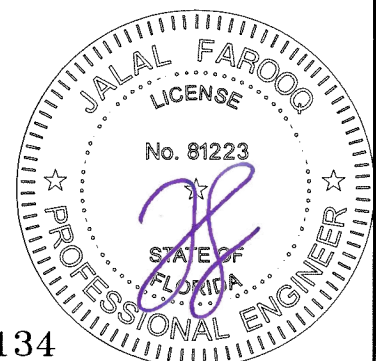

FL #31134

AL-FAROOQ CORPORATION
 ENGINEERS & PRODUCT DEVELOPMENT
 9360 SUNSET DRIVE, SUITE 220
 MIAMI, FLORIDA 33173 (C.A.N. 3598)
 TEL. (305) 264-8100 FAX. (305) 262-6978
 COMP-ANL \ 19-118F-SWM

SERIES-4230 ALUMINUM FIXED WDW. (L.M.I.)
Sunshine Windows Manufacturing, Inc.
 1785 West 33rd Place
 Hialeah, FL. 33012
 Tel. (305) 364-9952 Fax. (305) 828-5118

revisions:	no	date	by	description
date:	11-06-19	scale:	1/2" = 1"	
dr. by:	TARIQ	chk. by:		
drawing no.	19-118F			
sheet	5 of 5			