



[DBPR HOME](#) | [ABOUT DBPR](#) | [DBPR DIVISIONS](#) | [CONTACT DBPR](#)

[BCIS Home](#) | [Log In](#) | [User Registration](#) | [Hot Topics](#) | [Submit Surcharge](#) | [Stats & Facts](#) | [Publications](#) | [Contact Us](#) | [BCIS Site Map](#) | [Links](#) | [Search](#)



Product Approval
USER: Public User

[Product Approval Menu](#) > [Product or Application Search](#) > [Application List](#) > **Application Detail**

OFFICE OF THE SECRETARY

FL #	FL37315-R1										
Application Type	Revision										
Code Version	2023										
Application Status	Approved										
Comments											
Archived	<input type="checkbox"/>										
Product Manufacturer	Sunshine Windows Manufacturing Inc.										
Address/Phone/Email	1745 West 33rd Place Hialeah, FL 33012 (305) 364-9952 Ext 109 noel_m_2001@yahoo.com										
Authorized Signature	Jalal Farooq veronica@afceng.com										
Technical Representative											
Address/Phone/Email											
Quality Assurance Representative											
Address/Phone/Email											
Category	Panel Walls										
Subcategory	Storefronts										
Compliance Method	Evaluation Report from a Florida Registered Architect or a Licensed Florida Professional Engineer <input type="checkbox"/> Evaluation Report - Hardcopy Received										
Florida Engineer or Architect Name who developed the Evaluation Report	Jalal Farooq										
Florida License	PE-81223										
Quality Assurance Entity	Keystone Certifications, Inc.										
Quality Assurance Contract Expiration Date	02/28/2029										
Validated By	Abel Carrasco, PE <input checked="" type="checkbox"/> Validation Checklist - Hardcopy Received										
Certificate of Independence	FL37315 R1 COI SS - Certificate of Independence.pdf										
Referenced Standard and Year (of Standard)	<table border="0"> <thead> <tr> <th>Standard</th> <th>Year</th> </tr> </thead> <tbody> <tr> <td>AAMA 501</td> <td>2015</td> </tr> <tr> <td>TAS 201</td> <td>1994</td> </tr> <tr> <td>TAS 202</td> <td>1994</td> </tr> <tr> <td>TAS 203</td> <td>1994</td> </tr> </tbody> </table>	Standard	Year	AAMA 501	2015	TAS 201	1994	TAS 202	1994	TAS 203	1994
Standard	Year										
AAMA 501	2015										
TAS 201	1994										
TAS 202	1994										
TAS 203	1994										
Equivalence of Product Standards Certified By											
Sections from the Code											

Product Approval Method Method 1 Option D

Date Submitted 08/01/2023
 Date Validated 08/01/2023
 Date Pending FBC Approval 08/07/2023
 Date Approved 10/18/2023

Summary of Products

FL #	Model, Number or Name	Description
37315.1	Series 8000 Aluminum Window Wall System	Large missile impact resistant aluminum window wall system
Limits of Use Approved for use in HVHZ: Yes Approved for use outside HVHZ: Yes Impact Resistant: Yes Design Pressure: +130/-130 Other: See drawings 21-01F for span vs load combination and installation details.		Installation Instructions FL37315_R1_II_SS - 8000 WW (LMI) - DWG 21-01F (2023).pdf Verified By: Jalal Farooq PE #81223 Created by Independent Third Party: Yes Evaluation Reports FL37315_R1_AE_SS - 8000 WW (LMI)-PAE 2023.pdf Created by Independent Third Party: Yes

[Back](#) [Next](#)

Contact Us :: [2601 Blair Stone Road, Tallahassee FL 32399](#) Phone: 850-487-1824

The State of Florida is an AA/EEO employer. [Copyright 2007-2013 State of Florida](#). :: [Privacy Statement](#) :: [Accessibility Statement](#) :: [Refund Statement](#)

Under Florida law, email addresses are public records. If you do not want your e-mail address released in response to a public-records request, do not send electronic mail to this entity. Instead, contact the office by phone or by traditional mail. If you have any questions, please contact 850.487.1395. *Pursuant to Section 455.275(1), Florida Statutes, effective October 1, 2012, licensees licensed under Chapter 455, F.S. must provide the Department with an email address if they have one. The emails provided may be used for official communication with the licensee. However email addresses are public record. If you do not wish to supply a personal address, please provide the Department with an email address which can be made available to the public. To determine if you are a licensee under Chapter 455, F.S., please click [here](#).

Product Approval Accepts:



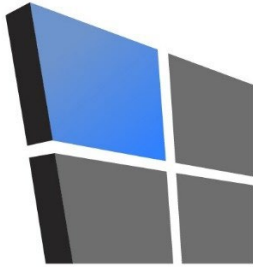

AL-FAROOQ CORPORATION

CONSULTING ENGINEERS & PRODUCT DEVELOPMENT

August 11, 2020

Product Approval Administrator
Building Codes & Standards Section
Department of Business & Professional Regulations
1940 North Monroe Street, Suite 90
Tallahassee, FL 32399-2100

To whom it may concern,

As the design engineer retained to prepare the product approval(s) associated with this letter as shown below on this same web page, I do hereby declare that I do not have and will not have any financial interest in any company manufacturing or distributing the referenced product(s), nor do I have or will have any financial interest with any other entity involved in the approval process of the referenced product(s).

Sincerely,



Sealed 8-11-2020

Jalal Farooq, P.E.
CFO

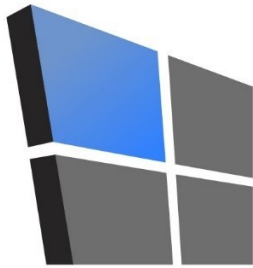

AL-FAROOQ CORPORATION

CONSULTING ENGINEERS & PRODUCT DEVELOPMENT

PRODUCT APPROVAL EVALUATION RULE CHAPTER #61G20-3 • METHOD 1 OPTION D

FL 37315

Date: 07/31/2023

Detailed Product Description:

Manufacturer: SUNSHINE WINDOWS MANUFACTURING, INC.

Manufacturer Address: 1785 W 33 PLACE, HIALEAH, FL 33012

Model Name: SERIES 8000 ALUMINUM WINDOW WALL SYSTEM

Maximum Load: +130PSF, -130 PSF (Large Missile Impact)

Installation Drawings # 21-01F

This product complies with the High Velocity Hurricane Zone (HVHZ) testing requirements.					
For maximum sizes, combination of span vs loads and anchor type refer to installation drawings.					
Comparative analysis used <input checked="" type="checkbox"/> Yes <input type="checkbox"/> No					
Mandatory Tests (Tested in accordance with AAMA 501/101/I.S.2/NAFS/TAS-202)					
TEST	DESCRIPTION	TEST LOCATION	TEST REPORT DATE	TEST REPORT #	Test Sealed by
ASTM E283	Air Infiltration Leakage	Fenestration Testing Laboratory, Inc.	12/19/2007 03/24/2016 08/16/2017 06/19/2020	FTL-5447 FTL-8372 FTL-9605 FTL-12112	Michael R. Wenzel, P.E. Idalmis Ortega, P.E. Idalmis Ortega, P.E. Idalmis Ortega, P.E.
		Blackwater Technical Services Inc.	05/17/2018 12/18/2020	BT-ESW-18-004 BT-ESW-20-036A	Constantin Bortes, P.E. Michael D. Caldwell, P.E.
ASTM E331 OR ASTM 547 & TAS 202	Water Penetration	Fenestration Testing Laboratory, Inc.	12/19/2007 03/24/2016 08/16/2017 06/19/2020	FTL-5447 FTL-8372 FTL-9605 FTL-12112	Michael R. Wenzel, P.E. Idalmis Ortega, P.E. Idalmis Ortega, P.E. Idalmis Ortega, P.E.
		Blackwater Technical Services Inc.	12/18/2020	BT-ESW-20-036A	Michael D. Caldwell, P.E.
ASTM E330 & TAS 202	Uniform Static Air Press.	Fenestration Testing Laboratory, Inc.	12/19/2007 03/24/2016 08/16/2017 06/19/2020	FTL-5447 FTL-8372 FTL-9605 FTL-12112	Michael R. Wenzel, P.E. Idalmis Ortega, P.E. Idalmis Ortega, P.E. Idalmis Ortega, P.E.
		Blackwater Technical Services Inc.	05/17/2018 01/12/2023	BT-ESW-18-004 BT-ESW-22-023	Constantin Bortes, P.E. Michael D. Caldwell, P.E.
ASTM F588	Forced Entry	Fenestration Testing Laboratory, Inc.	06/19/2020	FTL-12112	Idalmis Ortega, P.E.
		Blackwater Technical Services Inc.	12/18/2020	BT-ESW-20-036A	Michael D. Caldwell, P.E.

Supplemental Tests (Tested in accordance with TAS-201 and TAS-203)

TEST	DESCRIPTION	TEST LOCATION	TEST REPORT DATE	TEST REPORT #	Test Sealed by
FBC 1626.2 (TAS 201 & 203) ANSI Z97.1	Large Missile Impact & Cyclic	Fenestration Testing Laboratory, Inc.	12/19/2007 03/24/2016 08/16/2017 06/19/2020	FTL-5447 FTL-8372 FTL-9605 FTL-12112	Michael R. Wenzel, P.E. Idalmis Ortega, P.E. Idalmis Ortega, P.E. Idalmis Ortega, P.E.
		Blackwater Technical Services Inc.	05/17/2018 12/18/2020 01/12/2023	BT-ESW-18-004 BT-ESW-20-036A BT-ESW-22-023	Constantin Bortes, P.E. Michael D. Caldwell, P.E. Michael D. Caldwell, P.E.

Under the limitations of the attached installation drawings, to the best of my knowledge and ability, the above product conforms to the requirements of the 2023 Florida Building Code.

Evaluation Report Engineer:

Jalal Farooq PE # 81223
Al-Farooq Corporation EB # 3538



Sealed: 7/31/2023

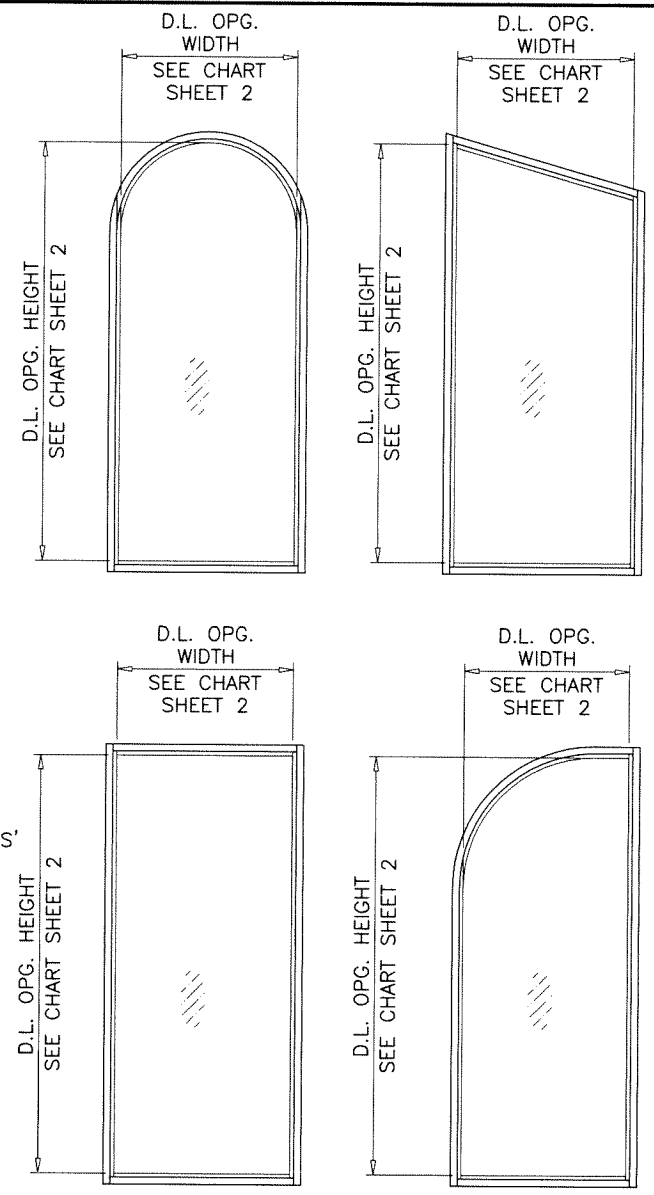
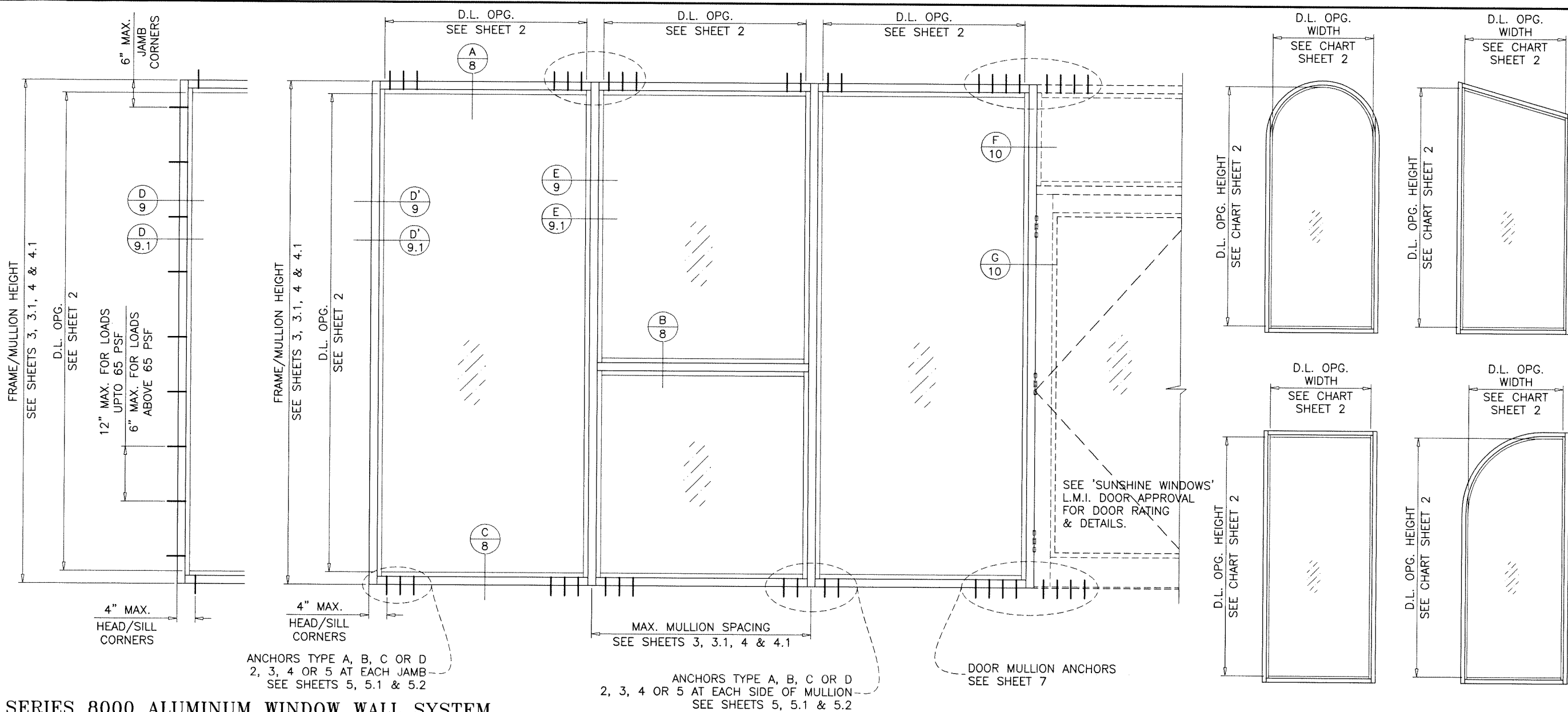

SERIES 8000 ALUMINUM WINDOW WALL SYSTEM

THIS SYSTEM IS RATED FOR LARGE MISSILE IMPACT
SHUTTERS ARE NOT REQUIRED.

THIS PRODUCT HAS BEEN DESIGNED AND TESTED TO COMPLY WITH THE REQUIREMENTS OF THE 2020 (7TH EDITION)/2023 (8TH EDITION) FLORIDA BUILDING CODE INCLUDING HIGH VELOCITY HURRICANE ZONE (HVHZ).

1BY OR 2BY WOOD BUCKS & BUCK FASTENERS BY OTHERS, MUST BE DESIGNED AND INSTALLED ADEQUATELY TO TRANSFER APPLIED PRODUCT LOADS TO THE BUILDING STRUCTURE.

ANCHORS SHALL BE CORROSION RESISTANT, SPACED AS SHOWN ON DETAILS AND INSTALLED PER MANUF'S INSTRUCTIONS. SPECIFIED EMBEDMENT TO BASE MATERIAL SHALL BE BEYOND WALL DRESSING OR STUCCO.

A LOAD DURATION INCREASE IS USED IN DESIGN OF ANCHORS INTO WOOD ONLY. ALL SHIMS TO BE HIGH IMPACT, NON-METALLIC AND NON-COMPRESSIBLE.

MATERIALS INCLUDING BUT NOT LIMITED TO STEEL/METAL SCREWS, THAT COME INTO CONTACT WITH OTHER DISSIMILAR MATERIALS SHALL MEET THE REQUIREMENTS OF THE 2020/2023 FLORIDA BLDG. CODE & ADOPTED STANDARDS.

THIS PRODUCT APPROVAL IS GENERIC AND DOES NOT PROVIDE INFORMATION FOR A SITE SPECIFIC PROJECT, i.e. LIFE SAFETY OF THIS PRODUCT, ADEQUACY OF STRUCTURE RECEIVING THIS PRODUCT AND SEALING AROUND OPENING FOR WATER INFILTRATION RESISTANCE ETC. CONDITIONS NOT SHOWN IN THIS DRAWING ARE TO BE ANALYZED SEPARATELY, AND TO BE REVIEWED BY BUILDING OFFICIAL.

DESIGN LOADS SHOWN ARE BASED ON 'ALLOWABLE STRESS DESIGN (ASD)'. MANUFACTURER'S LABEL SHALL BE LOCATED ON A READILY VISIBLE LOCATION IN ACCORDANCE WITH SECTION 1709.9.3 OF FLORIDA BUILDING CODE. LABELING TO COMPLY WITH SECTION 1709.9.2.

TYPICAL ELEVATION

INSTRUCTIONS:

USE CHARTS AS FOLLOWS.

- STEP 1** DETERMINE DESIGN WIND LOAD REQUIREMENT BASED ON WIND VELOCITY, BLDG. HEIGHT, WIND ZONE USING APPLICABLE ASCE 7 STANDARD.
- STEP 2** SEE CHARTS ON SHEET 2 FOR DESIGN LOAD CAPACITY OF DESIRED GLASS SIZE.
- STEP 3** CHECK MULLION CAPACITY FOR A GIVEN SPACING AND HEIGHT USING CHARTS ON SHEETS 3 & 4 FOR WINDOW WALL MULLION AND SHEETS 6 & 7 FOR DOOR MULLION. THE CAPACITY SHOULD EXCEED THE DESIGN LOAD.
- STEP 4** CHECK ANCHOR CAPACITY FOR WINDOW WALL SYSTEM USING CHARTS ON SHEETS 5, 5.1 & 5.2. FOR DOOR MULLION ANCHOR CAPACITY SEE CHART ON SHEET 7. THE CAPACITY SHOULD EXCEED THE DESIGN LOAD.
- STEP 5** THE LOWEST VALUE RESULTING FROM STEPS 2, 3 AND 4 SHALL APPLY TO ENTIRE SYSTEM.

ALLOWABLE LOADS FOR ALTERNATE SHAPES AS SHOWN ABOVE OR SIMILAR CAN BE VERIFIED BY INSCRIBING PICTURE WINDOW SHAPE WITHIN SQUARE OR RECTANGLE AS SHOWN IN DOTTED LINES AND OBTAINING ALLOWABLE LOADS FROM THOSE SHAPES. SINGLE LITES MAY BE INSTALLED VERTICALLY AS SHOWN ABOVE OR HORIZONTALLY.

PRODUCT COMPLIES WITH REQUIREMENTS OF ANSI Z97.1.

**LAMINATED GLASS
LARGE MISSILE IMPACT**

Sealed: 7/26/2023 FL #37315.1

- A- CONTRACTOR TO BE RESPONSIBLE FOR THE SELECTION, PURCHASE AND INSTALLATION OF THIS PRODUCT BASED ON THIS PRODUCT EVALUATION PROVIDED HE/SHE DOES NOT DEVIATE FROM THE CONDITIONS DETAILED ON THIS DOCUMENT.
- B- THIS PRODUCT EVALUATION DOCUMENT WILL BE CONSIDERED INVALID IF ALTERED BY ANY MEANS.
- C- SITE SPECIFIC PROJECTS SHALL BE PREPARED BY A FLORIDA REGISTERED ENGINEER OR ARCHITECT WHICH WILL BECOME THE ENGINEER OF RECORD (E.O.R.) FOR THE PROJECT AND WHO WILL BE RESPONSIBLE FOR THE PROPER USE OF THE P.E.D. ENGINEER OF RECORD, ACTING AS A DELEGATED ENGINEER TO THE P.E.D. ENGINEER SHALL SUBMIT TO THIS LATTER THE SITE SPECIFIC DRAWINGS FOR REVIEW.
- D- THIS P.E.D. SHALL BEAR THE DATE AND ORIGINAL SEAL AND SIGNATURE OF THE PROFESSIONAL ENGINEER OF RECORD THAT PREPARED IT.

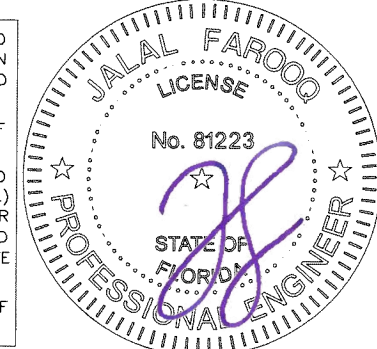

AL-FAROOQ CORPORATION
ENGINEERS & PRODUCT DEVELOPMENT
9360 SUNSET DRIVE, SUITE 220
MIAMI, FLORIDA 33173 (C.A.N. 3538)
TEL. (305) 264-8100 FAX. (305) 262-6978
STORE 21-01F-SW

SERIES 8000 ALUM WINDOW WALL SYSTEM (L.M.I.)
Sunshine Windows Manufacturing, Inc.
1785 West 33rd Place
Hialeah, FL. 33012
Tel. (305) 364-9952 Fax. (305) 828-5118

no	date	by	description
A	07.24.23		UPDATED TO 2023 FBC

date: 01-07-21
scale: 1/2"=1'-0"
dr. by: TARIQ
chk. by:

drawing no.
21-01F
sheet 1 of 12

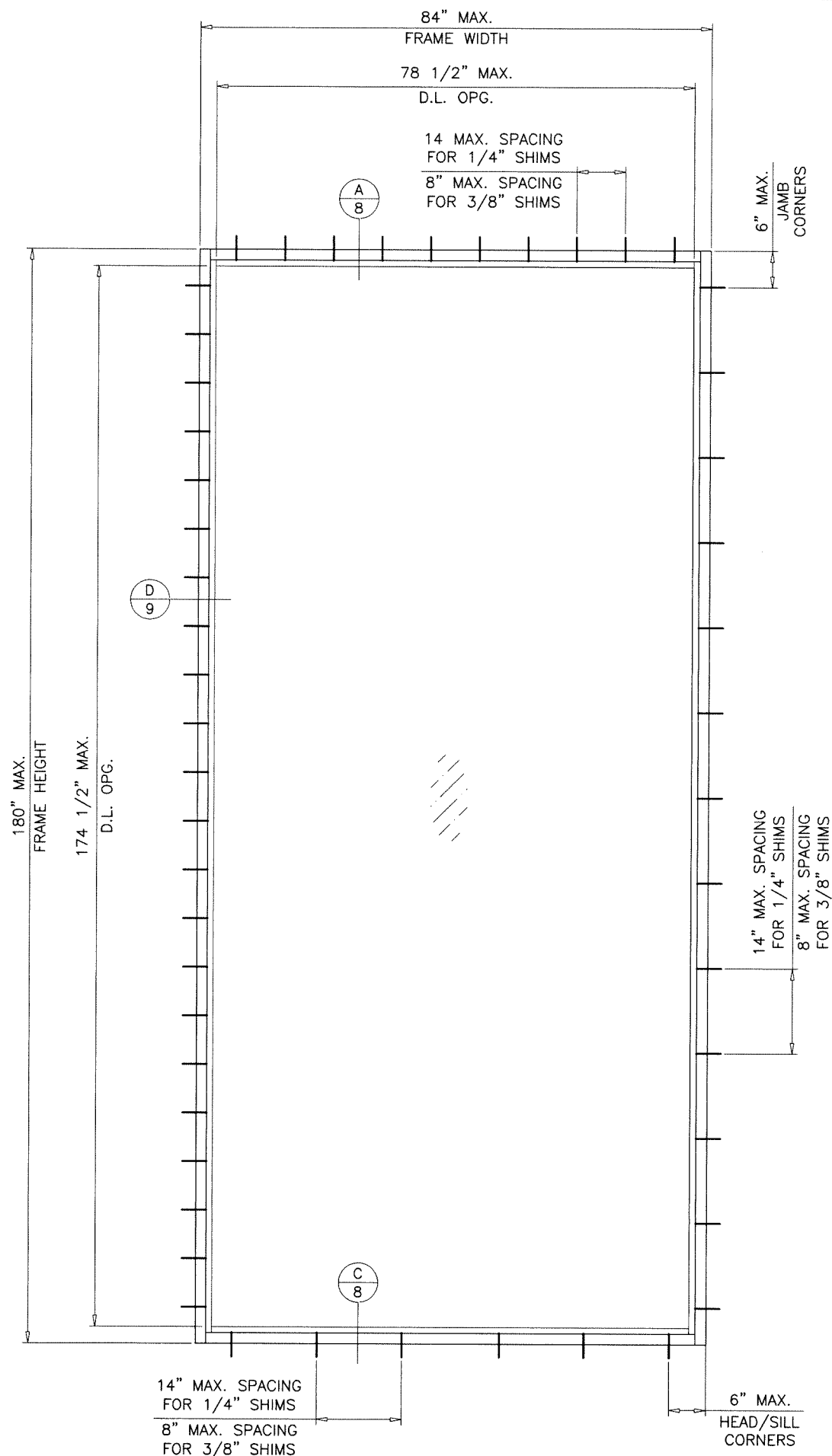

TYPICAL ELEVATION
SINGLE (O) PANEL

MAXIMUM DESIGN LOAD RATING = + 70.0 PSF
- 70.0 PSF
(ONLY FOR SINGLE UNITS SHOWN IN THIS SHEET OR SMALLER)

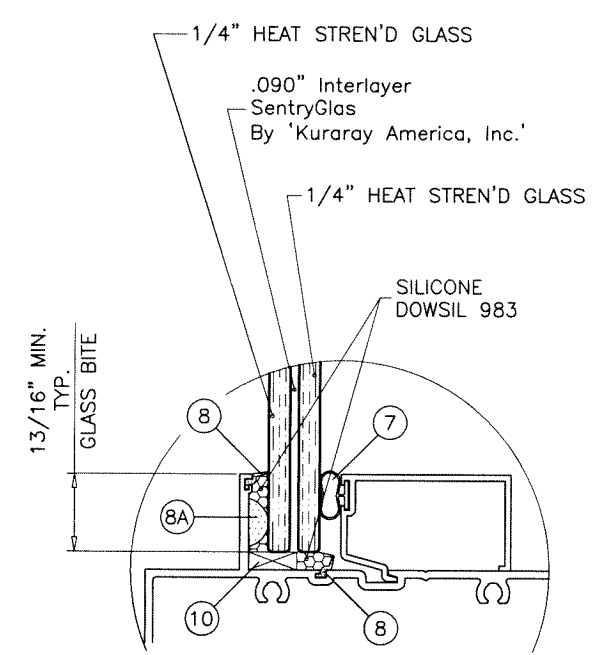

GLASS TYPE 'B1'

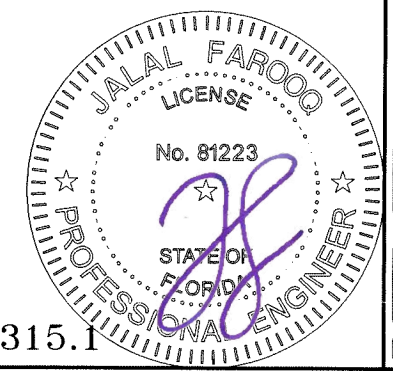

Sealed: 7/26/2023

FL #37315.1

afc
AL-FAROOQ CORPORATION
ENGINEERS & PRODUCT DEVELOPMENT
9360 SUNSET DRIVE, SUITE 220
MIAMI, FLORIDA 33173 (C.A.N. 3538)
TEL. (305) 264-8100 FAX. (305) 262-6978
STORE 21-01F-SW

SERIES 8000 ALUM WINDOW WALL SYSTEM (L.M.I.)
Sunshine Windows Manufacturing, Inc.
1785 West 33rd Place
Hialeah, FL. 33012
Tel. (305) 364-9952 Fax. (305) 828-5118

no	date	by	description

date: 01-07-21
scale: 1/2"=1'-0"
dr. by: TARIQ
chk. by:

drawing no.
21-01F
sheet 1.1 of 12

afc

AL-FAROOQ CORPORATION
 ENGINEERS & PRODUCT DEVELOPMENT
 9360 SUNSET DRIVE, SUITE 220
 MIAMI, FLORIDA 33173 (C.A.N. 3538)
 TEL. (305) 264-8100 FAX. (305) 262-6978

STORE\21-01F-SW

SERIES 8000 ALUM WINDOW WALL SYSTEM (L.M.I.)

Sunshine Windows Manufacturing, Inc.
 1785 West 33rd Place
 Hialeah, FL 33012
 Tel. (305) 364-9952 Fax. (305) 828-5118

no	date	by	description

date: 01-07-21	scale: 1/2"=1'-0"	dr. by: TARIQ	chk. by:
----------------	-------------------	---------------	----------

drawing no.
21-01F
 sheet 1.2 of 12

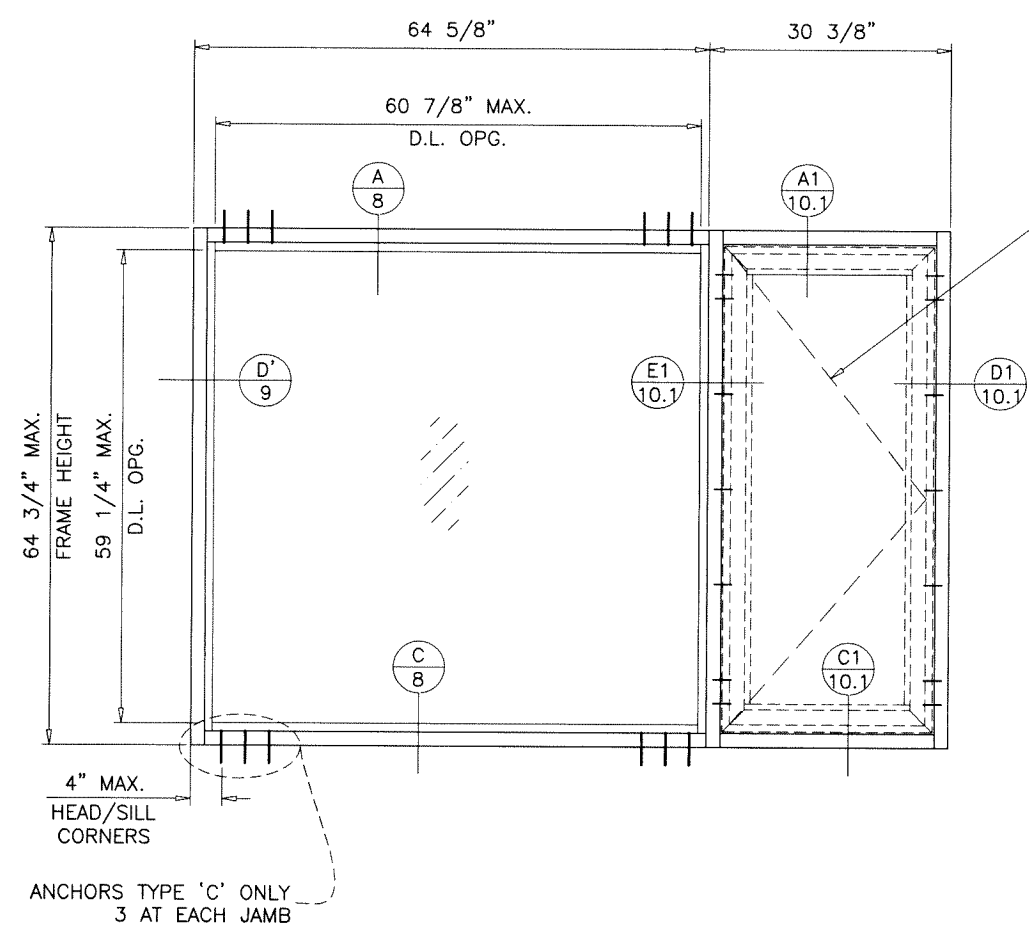

WINDOW WALL SYSTEM WITH WINDOW INSERT
 SEE SEPARATE APPROVAL FOR WINDOW CAPACITY
 LOWER RATING OF WINDOW OR
 WINDOW WALL SYSTEM WILL CONTROL.

MAXIMUM DESIGN LOAD RATING = + 78.0 PSF
- 114.0 PSF
 (ONLY FOR SINGLE UNITS SHOWN IN THIS SHEET)

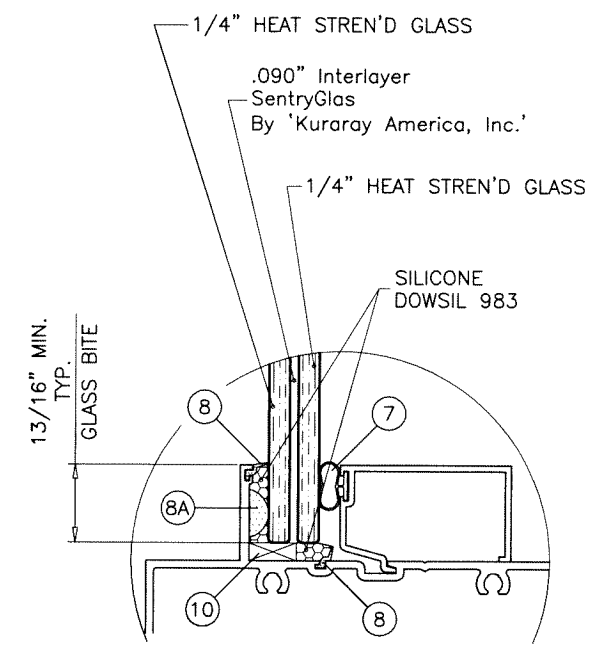

GLASS TYPE 'B1'

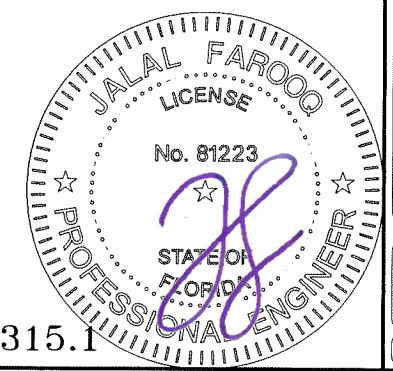

Sealed: 7/26/2023

FL #37315.1

GLASS LOAD CAPACITY - PSF			
NOMINAL DIMS.		GLASS TYPE 'A'	GLASS TYPE 'B'
D.L.O. WIDTH	D.L.O. HEIGHT	EXT.(+)/INT.(-)	EXT.(+)/INT.(-)
28"	84-1/2"	80.0	130.0
32"		80.0	130.0
36"		80.0	130.0
40"		80.0	130.0
44-1/4"		80.0	130.0
48"		80.0	130.0
52"		80.0	130.0
56-1/4"		80.0	130.0
60-1/2"		-	63.6
66-1/2"		-	58.3
28"	90-1/2"	80.0	130.0
32"		80.0	130.0
36"		80.0	130.0
40"		80.0	130.0
44-1/4"		80.0	130.0
48"		80.0	130.0
52"		80.0	130.0
54-1/2"		56.0	70.0
60-1/2"		-	63.6
66-1/2"		-	58.3
28"	96-1/2"	80.0	130.0
32"		80.0	130.0
36"		80.0	130.0
40"		80.0	130.0
44-1/4"		80.0	130.0
48"		80.0	130.0
52"		80.0	127.2
54-1/2"		56.0	70.0
60-1/2"		-	63.6
66-1/2"		-	58.3
28"	102-1/2"	80.0	130.0
32"		80.0	130.0
36"		80.0	130.0
40"		80.0	130.0
44-1/4"		80.0	130.0
48"		80.0	128.9
54-1/2"		56.0	70.0
60-1/2"		-	63.6
66-1/2"		-	58.3
28"		108-1/2"	80.0
32"	80.0		130.0
36"	80.0		130.0
40"	80.0		130.0
44-1/4"	80.0		130.0
48"	62.2		70.0
54-1/2"	56.0		70.0
60-1/2"	-		63.6
66-1/2"	-		58.3

GLASS LOAD CAPACITY - PSF			
NOMINAL DIMS.		GLASS TYPE 'A'	GLASS TYPE 'B'
D.L.O. WIDTH	D.L.O. HEIGHT	EXT.(+)/INT.(-)	EXT.(+)/INT.(-)
28"	114-1/2"	80.0	130.0
32"		80.0	130.0
36"		80.0	130.0
40"		80.0	130.0
44-1/4"		80.0	130.0
48-1/2"		62.2	90.0
51-1/2"		-	90.0
54-1/2"		-	70.0
60-1/2"		-	63.6
66-1/2"		-	58.3
44-1/4"	120-1/2"	70.0	90.0
48"		62.2	90.0
50"		-	90.0
54-1/2"		-	70.0
60-1/2"		-	63.6
42-1/4"	126-1/2"	70.0	90.0
44-1/4"		-	90.0
48"		-	90.0
48-1/2"		-	70.0
54-1/2"		-	70.0
40"	132-1/2"	70.0	90.0
42-1/4"		70.0	90.0
44-1/4"		-	90.0
46"		-	90.0
48-1/2"		-	70.0
54-1/2"	-	70.0	
40"	138-1/2"	70.0	90.0
42-1/4"		70.0	90.0
44-1/4"		-	90.0
48-1/2"		-	70.0
54-1/2"		-	70.0

NOTE:
INTERPOLATION BETWEEN WIDTHS ALLOWED.

NOTE:
GLASS CAPACITIES ON THIS SHEET ARE
BASED ON ASTM E1300-09 (3 SEC. GUSTS).

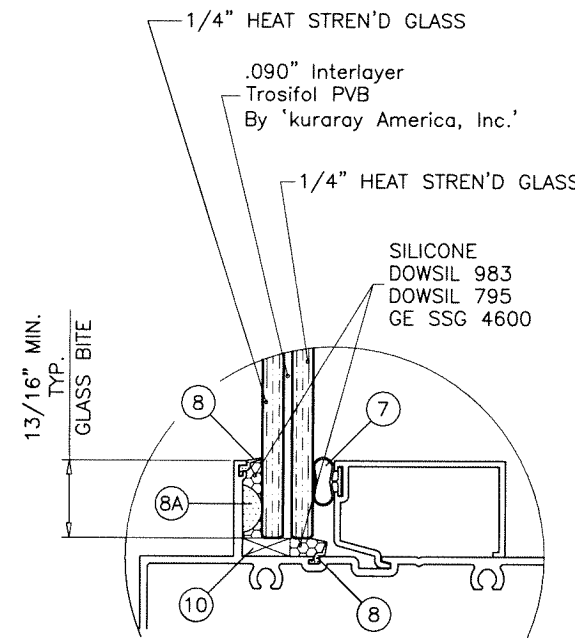
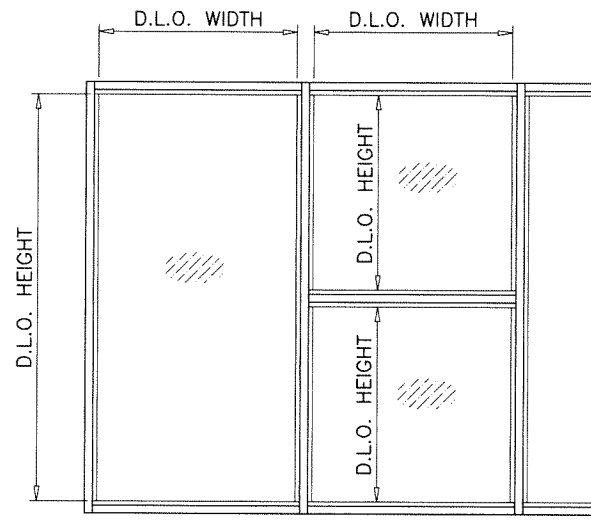

GLASS TYPE 'A'

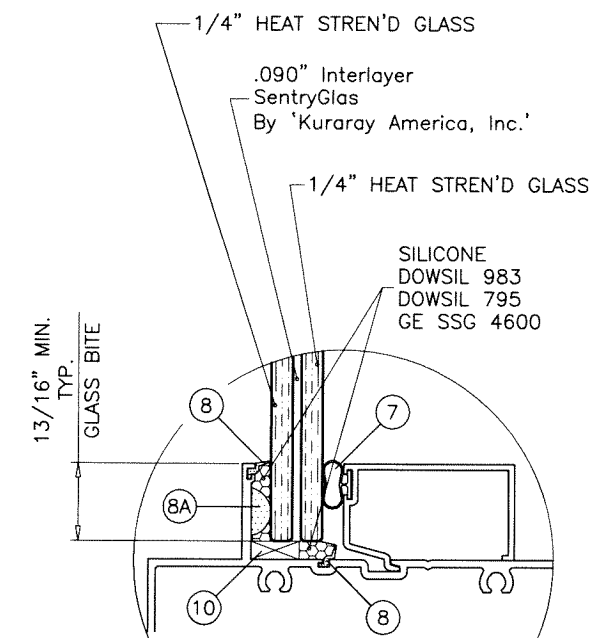

GLASS TYPE 'B'

GLAZING OPTIONS

GLASS

Sealed: 7/26/2023

FL #37315.1



AL-FAROOQ CORPORATION
ENGINEERS & PRODUCT DEVELOPMENT
9360 SUNSET DRIVE, SUITE 220
MIAMI, FLORIDA 33173 (C.A.N. 3538)
TEL. (305) 264-8100 FAX. (305) 262-6978
STORE 21-01F-SW

SERIES 8000 ALUM WINDOW WALL SYSTEM (L.M.I.)
Sunshine Windows Manufacturing, Inc.
1785 West 33rd Place
Hialeah, FL 33012
Tel. (305) 364-9952 Fax. (305) 828-5118

no	date	by	description

date: 01-07-21
scale: 1/2"=1'-0"
dr. by: TARIQ
chk. by:

drawing no.
21-01F
sheet 2 of 12

MULLION LOAD CAPACITY - PSF MULLIONS WITHOUT INTERMEDIATE HORIZONTALS						
NOMINAL DIMS.		JAMB 'J1'	JAMB 'J1'	JAMB 'J2'	JAMB 'J3'	UNANCHORED JAMB OPTIONS MULL OPTIONS
WIDTH (W)	FRAME HEIGHT	MULL 'M1'	MULL 'M2'	MULL 'M3'	MULL 'M4'	
		EXT. (+) INT. (-)	EXT. (+) INT. (-)	EXT. (+) INT. (-)	EXT. (+) INT. (-)	
30"	86-1/2"	130.0	130.0	130.0	130.0	
36"		130.0	130.0	130.0	130.0	
42"		130.0	130.0	130.0	130.0	
48"		130.0	130.0	130.0	130.0	
54"		130.0	130.0	130.0	130.0	
60"		127.3	130.0	130.0	130.0	
30"	90"	130.0	130.0	130.0	130.0	
36"		130.0	130.0	130.0	130.0	
42"		130.0	130.0	130.0	130.0	
48"		130.0	130.0	130.0	130.0	
54"		122.9	130.0	130.0	130.0	
60"		114.9	130.0	130.0	130.0	
30"	96"	130.0	130.0	130.0	130.0	
36"		130.0	130.0	130.0	130.0	
42"		121.1	130.0	130.0	130.0	
48"		108.6	130.0	130.0	130.0	
54"		99.4	130.0	125.6	130.0	
60"		92.4	130.0	116.3	130.0	
30"	98-1/2"	130.0	130.0	130.0	130.0	
36"		127.6	130.0	130.0	130.0	
42"		111.6	130.0	130.0	130.0	
48"		100.0	130.0	130.0	130.0	
54"		91.4	130.0	118.6	130.0	
58"		86.8	130.0	112.4	130.0	
30"	102"	130.0	130.0	130.0	130.0	
36"		114.5	130.0	130.0	130.0	
42"		100.0	130.0	130.0	130.0	
48"		89.5	130.0	120.9	130.0	
54"		81.6	130.0	109.8	130.0	
56"		79.4	127.7	106.7	130.0	
30"	108"	113.5	130.0	130.0	130.0	
36"		95.9	130.0	130.0	130.0	
42"		83.6	130.0	120.3	130.0	
48"		74.6	120.0	107.0	130.0	
53"		68.8	110.7	98.4	130.0	
30"		110-1/2"	105.9	130.0	130.0	130.0
36"	89.4		130.0	130.0	130.0	
42"	77.8		125.2	114.7	130.0	
48"	69.4		111.6	101.9	130.0	
52"	64.9		104.5	95.1	130.0	
30"	114"		96.2	130.0	130.0	130.0
36"		81.2	130.0	123.8	130.0	
42"		70.6	113.6	107.4	130.0	
48"		62.9	101.1	95.3	130.0	
50"		60.8	97.7	92.0	130.0	
30"		120"	82.3	130.0	130.0	130.0
36"	69.3		111.5	111.4	130.0	
42"	60.2		96.9	96.5	130.0	
48"	53.5		86.1	85.5	130.0	

NOTE:
INTERPOLATION BETWEEN WIDTHS ALLOWED.

MULLION LOAD CAPACITY - PSF MULLIONS W/O INTERMEDIATE HORIZONTALS				
NOMINAL DIMS.		JAMB 'J2'	JAMB 'J3'	UNANCHORED JAMB OPTIONS MULL OPTIONS
WIDTH (W)	FRAME HEIGHT	MULL 'M4'	MULL 'M4'	
		EXT. (+) INT. (-)	EXT. (+) INT. (-)	
54"	120"	90.0	90.0	
57"		90.0	90.0	
60"		-	70.0	
66"		-	70.0	
72"		-	70.0	
30"		126"	90.0	90.0
36"	90.0		90.0	
42"	90.0		90.0	
48"	90.0		90.0	
54"	90.0		90.0	
60"	-		70.0	
66"	-	70.0		
30"	132"	90.0	90.0	
36"		90.0	90.0	
42"		90.0	90.0	
48"		90.0	90.0	
52"		90.0	90.0	
54"		-	70.0	
60"	-	70.0		
30"	138"	90.0	90.0	
36"		90.0	90.0	
42"		90.0	90.0	
48"		90.0	90.0	
50"		86.9	86.9	
54"		-	70.0	
60"	-	64.9		
30"	144"	90.0	90.0	
36"		90.0	90.0	
42"		89.4	89.4	
48"		79.0	79.0	
54"		-	65.1	
60"		-	59.3	

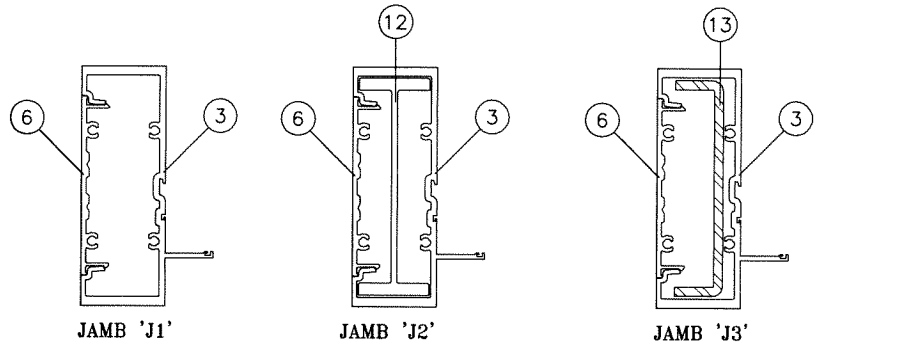

I_x IN ⁴	S_x IN ³	I_x IN ⁴	S_x IN ³	I_x IN ⁴	S_x IN ³
6.6509	2.6421	10.6486	4.4452	6.6509	2.6421
ALUMINUM				6.6509	2.6421
STEEL				2.7506	1.2225
TOTAL				14.6276	
I_x ALUM + I_x STL X 2.9				14.6276	

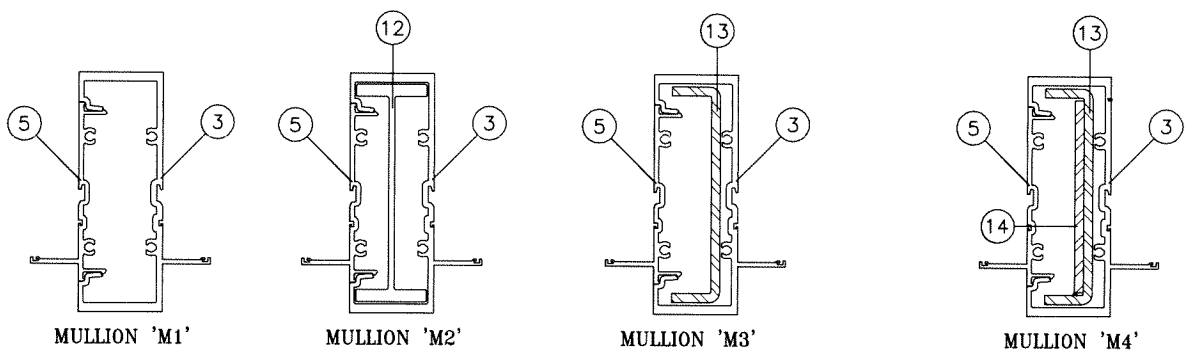

I_x IN ⁴	S_x IN ³	I_x IN ⁴	S_x IN ³	I_x IN ⁴	S_x IN ³
6.7195	2.6757	10.8072	3.7590	6.7195	2.6757
ALUMINUM				6.7195	2.6757
STEEL				2.7506	1.2225
TOTAL				14.6962	
I_x ALUM + I_x STL X 2.9				14.6962	

I_x IN ⁴	S_x IN ³	I_x IN ⁴	S_x IN ³
6.7195	2.6757	3.7533	1.668
ALUMINUM		6.7195	2.6757
STEEL		3.7533	1.668
TOTAL		17.6047	
I_x ALUM + I_x STL X 2.9		17.6047	

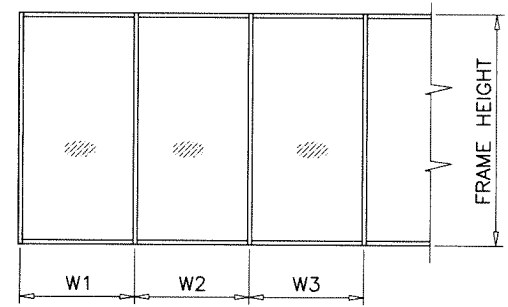

WIDTH (W) = W1
AT FRAME JAMB

WIDTH (W) = $\frac{W2 + W3}{2}$
AT FRAME MULLION

MULLIONS

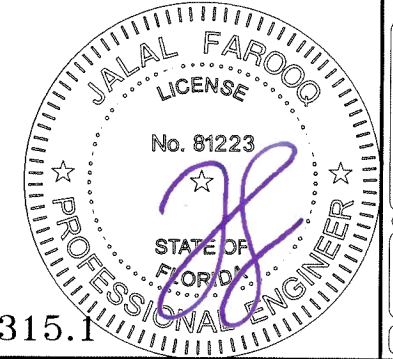

Sealed: 7/26/2023

FL #37315.1

af c
AL-FAROOQ CORPORATION
ENGINEERS & PRODUCT DEVELOPMENT
9360 SUNSET DRIVE, SUITE 220
MIAMI, FLORIDA 33173 (C.A.N. 3538)
TEL. (305) 262-6978 FAX. (305) 264-8100

SERIES 8000 ALUM WINDOW WALL SYSTEM (L.M.I.)
Sunshine Windows Manufacturing, Inc.
1785 West 33rd Place
Hialeah, FL 33012
Tel. (305) 364-9952 Fax. (305) 828-5118

revisions:	no.	date	by	description
date:	01-07-21	scale:	-	
dr. by:	TARIQ	chk. by:		
drawing no.	21-01F			
sheet	3 of 12			

STORE 21-01F-SW

MULLION LOAD CAPACITY - PSF MULLIONS WITHOUT INTERMEDIATE HORIZONTALS			
NOMINAL DIMS.		JAMB 'J1A'	JAMB 'J1A'
WIDTH (W)	FRAME HEIGHT	MULL 'M1A'	MULL 'M2A'
		EXT. (+) INT. (-)	EXT. (+) INT. (-)
30"	86-1/2"	60.0	70.0
36"		60.0	70.0
42"		60.0	70.0
48"		60.0	70.0
54"		60.0	70.0
60"		60.0	70.0
30"	90"	60.0	70.0
36"		60.0	70.0
42"		60.0	70.0
48"		60.0	70.0
54"		60.0	70.0
60"		60.0	70.0
30"	96"	60.0	70.0
36"		60.0	70.0
42"		60.0	70.0
48"		60.0	70.0
54"		55.6	70.0
60"		51.5	70.0
30"	98-1/2"	60.0	70.0
36"		60.0	70.0
42"		60.0	70.0
48"		57.6	70.0
54"		52.4	70.0
60"		-	-
30"	102"	60.0	70.0
36"		60.0	70.0
42"		59.7	70.0
48"		53.2	70.0
54"		48.3	70.0
60"		-	-
30"	108"	60.0	70.0
36"		60.0	70.0
42"		52.6	70.0
48"		46.8	70.0
54"		-	70.0
60"		-	70.0
30"	110-1/2"	60.0	70.0
36"		57.1	70.0
42"		49.7	70.0
48"		44.3	70.0
54"		-	70.0
60"		-	70.0
30"	114"	60.0	70.0
36"		51.8	70.0
42"		45.1	70.0
48"		40.1	70.0
54"		-	70.0
60"		-	-
30"	120"	52.5	70.0
36"		44.3	70.0
42"		38.5	70.0
48"		34.2	66.7
54"		-	60.4
57"		-	57.8

MULLION LOAD CAPACITY - PSF MULLIONS WITHOUT INTERMEDIATE HORIZONTALS			
NOMINAL DIMS.		JAMB 'J1A'	JAMB 'J1A'
WIDTH (W)	FRAME HEIGHT	MULL 'M1A'	MULL 'M2A'
		EXT. (+) INT. (-)	EXT. (+) INT. (-)
30"	126"	-	70.0
36"		-	70.0
42"		-	64.6
48"		-	57.3
54"		-	51.8
60"		-	-
30"	132"	-	70.0
36"		-	64.5
42"		-	55.9
48"		-	49.6
52"		-	46.2
60"		-	-
30"	138"	-	67.1
36"		-	56.3
42"		-	48.8
48"		-	43.2
50"		-	41.6
60"		-	-
30"	144"	-	58.9
36"		-	49.5
42"		-	42.8
48"		-	37.8
54"		-	-
60"		-	-

UNANCHORED
JAMB OPTIONS
MULL OPTIONS

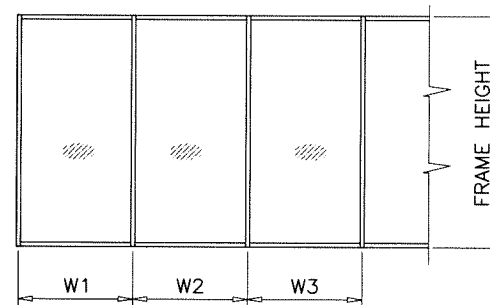

WIDTH (W) = W1
AT FRAME JAMB

WIDTH (W) = $\frac{W2 + W3}{2}$
AT FRAME MULLION

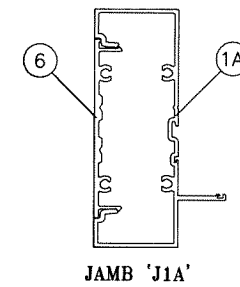

Ix IN ⁴	Sx IN ³
4.1316	1.6902

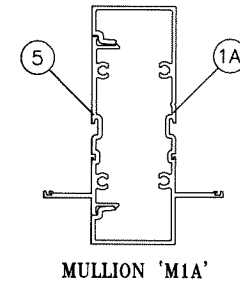

Ix IN ⁴	Sx IN ³
4.2902	1.7239

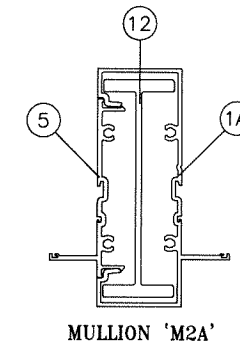

Ix IN ⁴	Sx IN ³
8.3779	3.527

MULLIONS

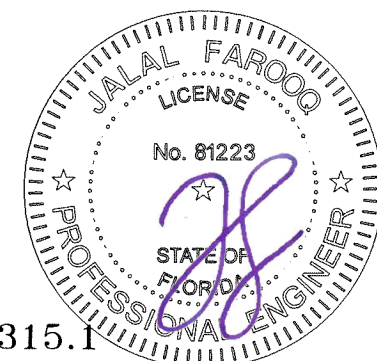

Sealed: 7/26/2023

FL #37315.1

NOTE:
INTERPOLATION BETWEEN WIDTHS ALLOWED.

af c
AL-FAROOQ CORPORATION
ENGINEERS & PRODUCT DEVELOPMENT
9360 SUNSET DRIVE, SUITE 220
MIAMI, FLORIDA 33173 (C.A.N. 3538)
TEL. (305) 264-8100 FAX. (305) 262-6978
STORE 21-01F-SW

SERIES 8000 ALUM WINDOW WALL SYSTEM (L.M.I.)
Sunshine Windows Manufacturing, Inc.
1785 West 33rd Place
Hialeah, FL. 33012
Tel. (305) 364-9952 Fax. (305) 828-5118

revisions:	no	date	by	description
date:	01-07-21	scale:	-	dr. by: TARIQ
chk. by:				
drawing no.	21-01F			
sheet	3.1 of 12			



AL-FAROOQ CORPORATION
 ENGINEERS & PRODUCT DEVELOPMENT
 9360 SUNSET DRIVE, SUITE 220
 MIAMI, FLORIDA 33173 (C.A.N. 35398)
 TEL. (305) 264-8100 FAX. (305) 262-6978

SERIES 8000 ALUM WINDOW WALL SYSTEM (L.M.I.)
Sunshine Windows Manufacturing, Inc.
 1785 West 33rd Place
 Hialeah, FL 33012
 Tel. (305) 364-9952 Fax. (305) 828-5118

revisions:	no	date	by	description

date: 01-07-21
 scale: -
 dr. by: TARIQ
 chk. by:

drawing no.
21-01F
 sheet 4 of 12

MULLION LOAD CAPACITY - PSF
MULLIONS WITH INTERMEDIATE HORIZONTALS

NOMINAL DIMS.		JAMB 'J1'	JAMB 'J1'	JAMB 'J2'	JAMB 'J3'	JAMB 'J3'	UNANCHORED JAMB OPTIONS MULL OPTIONS
WIDTH (W)	FRAME HEIGHT	MULL 'M1'	MULL 'M2'	MULL 'M3'	MULL 'M4'	MULL 'M4'	
		EXT. (+) INT. (-)	EXT. (+) INT. (-)	EXT. (+) INT. (-)	EXT. (+) INT. (-)	EXT. (+) INT. (-)	
30"	78"	130.0	130.0	130.0	130.0	130.0	
36"		130.0	130.0	130.0	130.0	130.0	
42"		130.0	130.0	130.0	130.0	130.0	
48"		130.0	130.0	130.0	130.0	130.0	
54"		130.0	130.0	130.0	130.0	130.0	
60"		130.0	130.0	130.0	130.0	130.0	
30"	86-1/2"	130.0	130.0	130.0	130.0	130.0	
36"		130.0	130.0	130.0	130.0	130.0	
42"		130.0	130.0	130.0	130.0	130.0	
48"		130.0	130.0	130.0	130.0	130.0	
54"		118.9	130.0	130.0	130.0	130.0	
60"		107.0	130.0	130.0	124.8	130.0	
30"	90"	130.0	130.0	130.0	130.0	130.0	
36"		130.0	130.0	130.0	130.0	130.0	
42"		130.0	130.0	130.0	130.0	130.0	
48"		119.2	130.0	130.0	130.0	130.0	
54"		105.9	130.0	130.0	128.1	130.0	
60"		95.3	130.0	130.0	115.3	130.0	
30"	96"	130.0	130.0	130.0	130.0	130.0	
36"		130.0	130.0	130.0	130.0	130.0	
42"		112.2	130.0	130.0	130.0	130.0	
48"		98.2	130.0	126.7	130.0	130.0	
54"		87.3	130.0	112.6	130.0	130.0	
60"		78.5	122.1	101.4	130.0	130.0	
30"	98-1/2"	130.0	130.0	130.0	130.0	130.0	
36"		121.2	130.0	130.0	130.0	130.0	
42"		103.9	130.0	130.0	130.0	130.0	
48"		90.9	130.0	120.3	130.0	130.0	
54"		80.8	128.9	107.0	130.0	130.0	
58"		75.2	120.0	99.6	130.0	130.0	
30"	102"	130.0	130.0	130.0	130.0	130.0	
36"		109.1	130.0	130.0	130.0	130.0	
42"		93.6	130.0	128.3	130.0	130.0	
48"		81.9	130.0	112.2	130.0	130.0	
54"		72.8	117.0	99.8	130.0	130.0	
56"		70.2	112.8	96.2	130.0	130.0	
30"	108"	110.3	130.0	130.0	130.0	130.0	
36"		91.9	130.0	130.0	130.0	130.0	
42"		78.8	126.8	114.4	130.0	130.0	
48"		69.0	110.9	100.1	130.0	130.0	
53"		62.5	100.4	90.7	130.0	130.0	
30"		110-1/2"	103.0	130.0	130.0	130.0	130.0
36"	85.8		130.0	127.5	130.0	130.0	
42"	73.6		118.3	109.3	130.0	130.0	
48"	64.4		103.6	95.6	130.0	130.0	
52"	59.4		95.6	88.3	130.0	130.0	
30"	114"		93.8	130.0	130.0	130.0	130.0
36"		78.2	125.7	119.8	130.0	130.0	
42"		67.0	107.8	102.7	130.0	130.0	
48"		58.6	94.3	89.8	130.0	130.0	
50"		56.3	90.5	86.2	130.0	130.0	
30"		120"	80.4	129.4	129.7	130.0	130.0
36"	67.0		107.8	108.1	130.0	130.0	
42"	57.5		92.4	92.7	130.0	130.0	
48"	50.3		80.9	81.1	130.0	130.0	

MULLION LOAD CAPACITY - PSF
MULLIONS WITH INTERMEDIATE HORIZONTALS

NOMINAL DIMS.		JAMB 'J2'	JAMB 'J3'	JAMB 'J3'	UNANCHORED JAMB OPTIONS MULL OPTIONS	
WIDTH (W)	FRAME HEIGHT	MULL 'M4'	MULL 'M4'	MULL 'M4'		
		EXT. (+) INT. (-)	EXT. (+) INT. (-)	EXT. (+) INT. (-)		
54"	120"	90.0	90.0	90.0		
57"		90.0	90.0	90.0		
30"	126"	90.0	90.0	90.0		
36"		90.0	90.0	90.0		
42"		90.0	90.0	90.0		
48"		90.0	90.0	90.0		
54"		90.0	90.0	90.0		
60"		-	70.0	70.0	70.0	
30"	132"	90.0	90.0	90.0		
36"		90.0	90.0	90.0		
42"		90.0	90.0	90.0		
48"		90.0	90.0	90.0		
52"		90.0	90.0	90.0		
54"		-	70.0	70.0	70.0	
30"	138"	90.0	90.0	90.0		
36"		90.0	90.0	90.0		
42"		90.0	90.0	90.0		
48"		86.6	86.6	86.6	86.6	
50"		83.1	83.1	83.1	83.1	
54"		-	67.7	67.7	67.7	
30"	144"	90.0	90.0	90.0		
36"		90.0	90.0	90.0		
42"		87.1	87.1	87.1	87.1	
48"		76.2	76.2	76.2	76.2	
54"		-	62.2	62.2	62.2	
60"		-	55.9	55.9	55.9	

NOTE: INTERPOLATION BETWEEN WIDTHS ALLOWED.

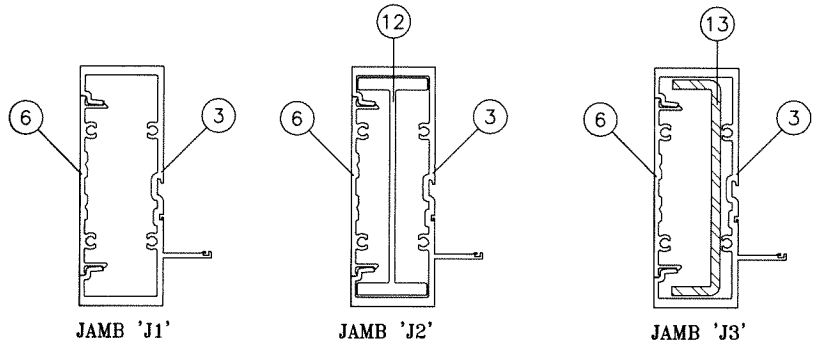

I_x IN ⁴	S_x IN ³	I_x IN ⁴	S_x IN ³	I_x IN ⁴	S_x IN ³
6.6509	2.6421	10.6486	4.4452	6.6509	2.6421
ALUMINUM		STEEL		TOTAL	
6.6509		2.7506		14.6276	
6.6509		2.7506		14.6276	
6.6509		2.7506		14.6276	

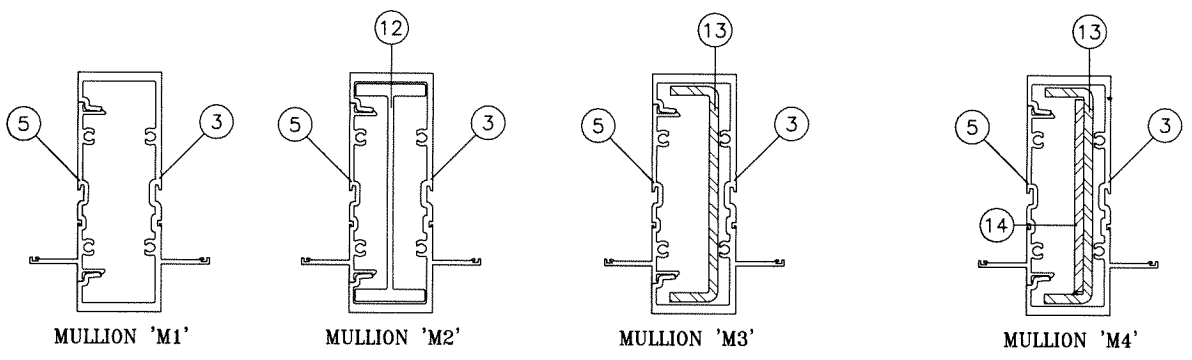

I_x IN ⁴	S_x IN ³	I_x IN ⁴	S_x IN ³	I_x IN ⁴	S_x IN ³
6.7195	2.6757	10.8072	3.7590	6.7195	2.6757
ALUMINUM		STEEL		TOTAL	
6.7195		2.6757		14.6962	
6.7195		2.6757		14.6962	
6.7195		2.6757		14.6962	

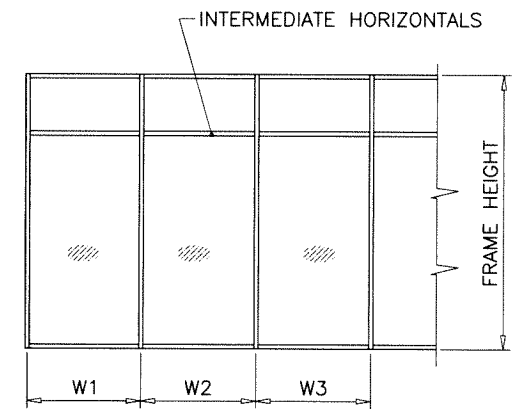

WIDTH (W) = W1
 AT FRAME JAMB

WIDTH (W) = $\frac{W2 + W3}{2}$
 AT FRAME MULLION

MULLIONS

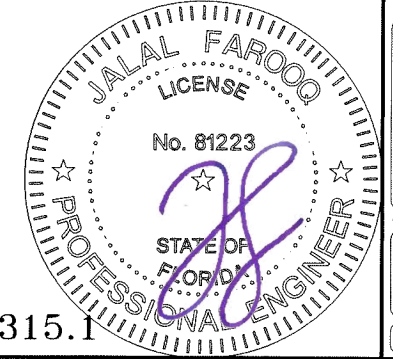

Sealed: 7/26/2023

FL #37315.1

MULLION LOAD CAPACITY - PSF MULLIONS WITH INTERMEDIATE HORIZONTALS			
NOMINAL DIMS.		JAMB 'J1A'	JAMB 'J1A'
WIDTH (W)	FRAME HEIGHT	MULL 'M1A'	MULL 'M2A'
		EXT. (+) INT. (-)	EXT. (+) INT. (-)
30"	86-1/2"	60.0	70.0
36"		60.0	70.0
42"		60.0	70.0
48"		60.0	70.0
54"		60.0	70.0
60"		55.9	70.0
30"	90"	60.0	70.0
36"		60.0	70.0
42"		60.0	70.0
48"		60.0	70.0
54"		57.1	70.0
60"		51.4	70.0
30"	96"	60.0	70.0
36"		60.0	70.0
42"		60.0	70.0
48"		56.1	70.0
54"		49.9	70.0
60"		44.9	70.0
30"	98-1/2"	60.0	70.0
36"		60.0	70.0
42"		60.0	70.0
48"		53.2	70.0
54"		47.2	70.0
30"	102"	60.0	70.0
36"		60.0	70.0
42"		56.4	70.0
48"		49.4	70.0
54"		43.9	70.0
30"	108"	60.0	70.0
36"		58.4	70.0
42"		50.0	70.0
48"		43.8	70.0
54"		-	70.0
60"		-	70.0
30"	110-1/2"	60.0	70.0
36"		54.8	70.0
42"		47.0	70.0
48"		41.1	70.0
54"		-	70.0
60"		-	70.0
30"	114"	59.9	70.0
36"		49.9	70.0
42"		42.8	70.0
48"		37.4	70.0
54"		-	70.0
30"	120"	51.4	70.0
36"		42.8	70.0
42"		36.7	70.0
48"		32.1	66.7
54"		-	60.4
57"		-	57.8

MULLION LOAD CAPACITY - PSF MULLIONS WITH INTERMEDIATE HORIZONTALS			
NOMINAL DIMS.		JAMB 'J1A'	JAMB 'J1A'
WIDTH (W)	FRAME HEIGHT	MULL 'M1A'	MULL 'M2A'
		EXT. (+) INT. (-)	EXT. (+) INT. (-)
30"	126"	-	70.0
36"		-	70.0
42"		-	64.6
48"		-	57.3
54"		-	51.8
30"	132"	-	70.0
36"		-	64.5
42"		-	55.9
48"		-	49.6
52"		-	46.2
30"	138"	-	67.1
36"		-	56.3
42"		-	48.8
48"		-	43.2
50"		-	41.6
30"	144"	-	58.9
36"		-	49.5
42"		-	42.8
48"		-	37.8

UNANCHORED
JAMB OPTIONS
MULL OPTIONS

NOTE:
INTERPOLATION BETWEEN WIDTHS ALLOWED.

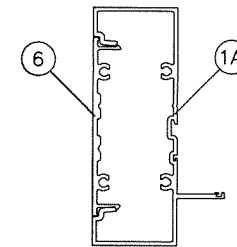

JAMB 'J1A'

Ix IN ⁴	Sx IN ³
4.1316	1.6902

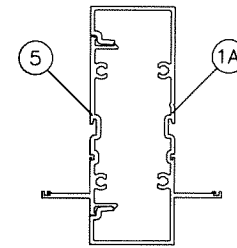

MULLION 'M1A'

Ix IN ⁴	Sx IN ³
4.2902	1.7239

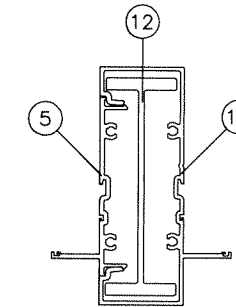

MULLION 'M2A'

Ix IN ⁴	Sx IN ³
8.3779	3.527

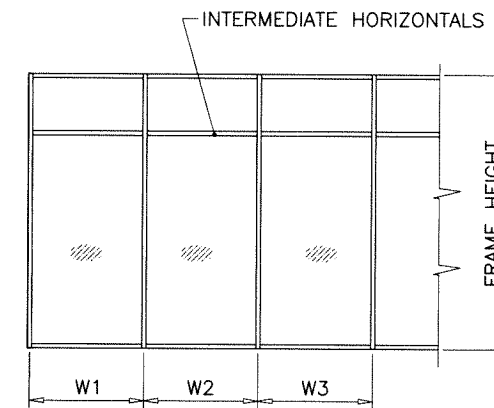

WIDTH (W) = W1
AT FRAME JAMB

WIDTH (W) = $\frac{W2 + W3}{2}$
AT FRAME MULLION

MULLIONS



Sealed: 7/26/2023

FL #37315.1

af c
AL-FAROOQ CORPORATION
ENGINEERS & PRODUCT DEVELOPMENT
9360 SUNSET DRIVE, SUITE 220
MIAMI, FLORIDA 33173 (C.A.N. 3538)
TEL. (305) 264-8100 FAX. (305) 264-6978

SERIES 8000 ALUM WINDOW WALL SYSTEM (L.M.I.)
Sunshine Windows Manufacturing, Inc.
1785 West 33rd Place
Hialeah, FL 33012
Tel. (305) 364-9952 Fax. (305) 828-5118

revisions:	no	date	by	description

date: 01-07-21	scale: -	dr. by: TARIQ	chk. by:
----------------	----------	---------------	----------

drawing no.
21-01F
sheet 4.1 of 12

STORE 21-01F-SW

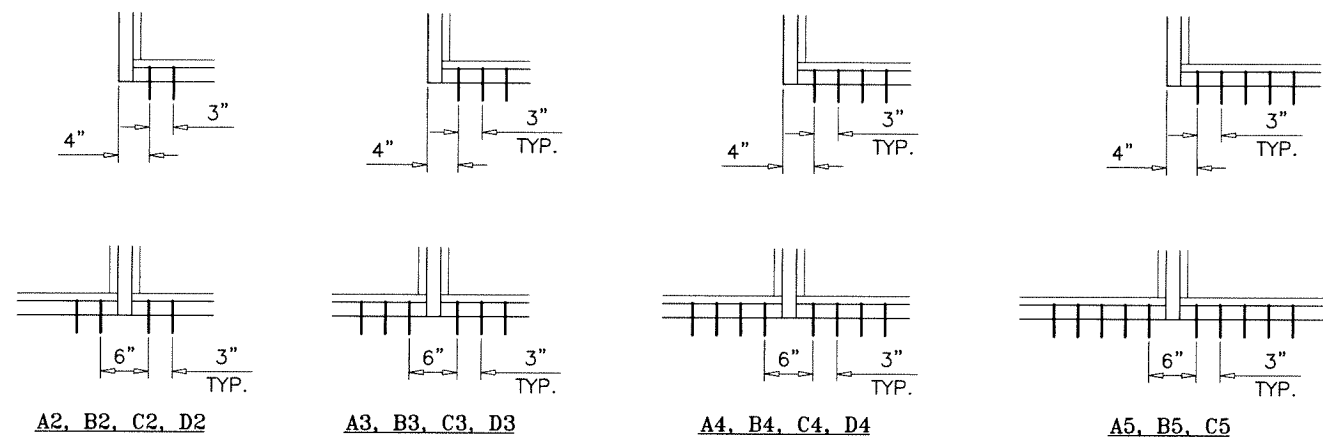
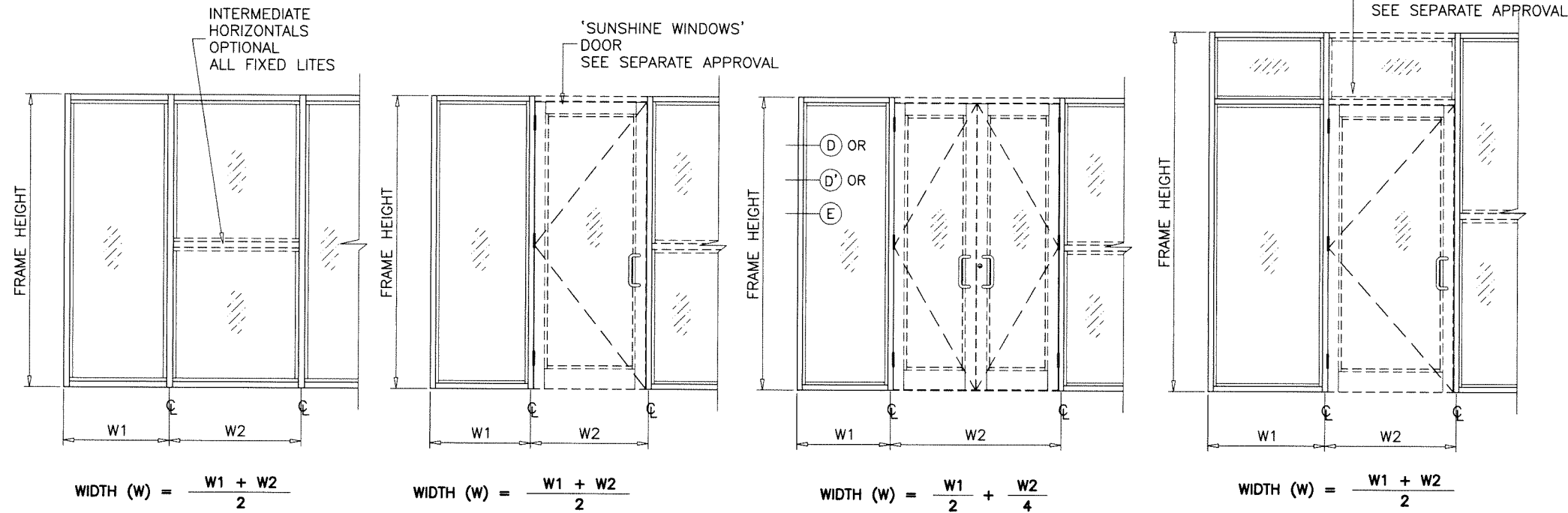

ANCHORS TYPES: SEE SHEET 8 FOR DESCRIPTION

- A2 = (2) ANCHORS TYPE 'A' AT EACH SIDE OF JAMB AND MULLION
- B2 = (2) ANCHORS TYPE 'B' AT EACH SIDE OF JAMB AND MULLION
- C2 = (2) ANCHORS TYPE 'C' AT EACH SIDE OF JAMB AND MULLION
- D2 = (2) ANCHORS TYPE 'D' AT EACH SIDE OF JAMB AND MULLION
- A3 = (3) ANCHORS TYPE 'A' AT EACH SIDE OF JAMB AND MULLION
- B3 = (3) ANCHORS TYPE 'B' AT EACH SIDE OF JAMB AND MULLION
- C3 = (3) ANCHORS TYPE 'C' AT EACH SIDE OF JAMB AND MULLION
- D3 = (3) ANCHORS TYPE 'D' AT EACH SIDE OF JAMB AND MULLION
- A4 = (4) ANCHORS TYPE 'A' AT EACH SIDE OF JAMB AND MULLION
- B4 = (4) ANCHORS TYPE 'B' AT EACH SIDE OF JAMB AND MULLION
- C4 = (4) ANCHORS TYPE 'C' AT EACH SIDE OF JAMB AND MULLION
- D4 = (4) ANCHORS TYPE 'D' AT EACH SIDE OF JAMB AND MULLION
- A5 = (5) ANCHORS TYPE 'A' AT EACH SIDE OF JAMB AND MULLION
- B5 = (5) ANCHORS TYPE 'B' AT EACH SIDE OF JAMB AND MULLION
- C5 = (5) ANCHORS TYPE 'C' AT EACH SIDE OF JAMB AND MULLION

ALL OTHER ANCHORS TO BE SPACED AS PER ELEVATION.

SEE SHEETS 5, 5.1, 5.2 & 7 FOR ANCHOR CAPACITY CHART.
SEE SHEET 8 FOR ANCHOR DESCRIPTION.

ANCHORS

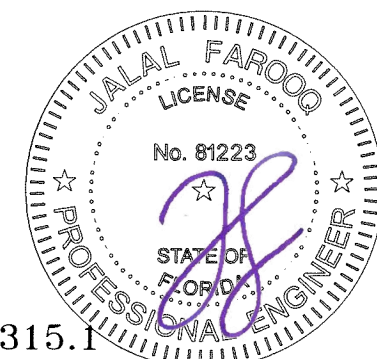

Sealed: 7/26/2023

FL #37315.1

af c

AL-FAROOQ CORPORATION
ENGINEERS & PRODUCT DEVELOPMENT
9360 SUNSET DRIVE, SUITE 220
MIAMI, FLORIDA 33173 (C.A.N. 3538)
TEL. (305) 264-8100 FAX. (305) 262-6978

SERIES 8000 ALUM WINDOW WALL SYSTEM (L.M.I.)

Sunshine Windows Manufacturing, Inc.
1785 West 33rd Place
Hialeah, FL 33012
Tel. (305) 364-9952 Fax. (305) 828-5118

no	date	by	description

date: 01-07-21
scale: -
dr. by: TARIQ
chk. by:

drawing no.
21-01F

sheet 5 of 12

STORE 21-01F-SW

ANCHOR LOAD CAPACITY - PSF
EXT.(+) & INT.(-)

NOMINAL DIMS.		ANCHORS TYPE 'A'								ANCHORS TYPE 'B'								ANCHORS TYPE 'C'								1/4" MAX. SHIM		
		3/8" SHIM SPACE				1/2" SHIM SPACE				3/8" SHIM SPACE				1/2" SHIM SPACE				3/8" SHIM SPACE				1/2" SHIM SPACE				ANCHORS TYPE 'D'		
WIDTH (W)	FRAME HEIGHT	A2	A3	A4	A5	A2	A3	A4	A5	B2	B3	B4	B5	B2	B3	B4	B5	C2	C3	C4	C5	C2	C3	C4	C5	D2	D3	D4
30"	110-1/2"	46.3	69.4	92.5	115.6	36.1	54.2	72.2	90.3	53.2	79.8	106.3	130.0	41.7	62.6	83.4	104.3	90.7	130.0	130.0	130.0	71.6	107.4	130.0	130.0	130.0	130.0	130.0
36"		38.5	57.8	77.1	96.4	30.1	45.1	60.2	75.2	44.3	66.5	88.6	110.8	34.8	52.1	69.5	86.9	75.6	112.9	130.0	130.0	59.7	89.5	119.3	130.0	113.2	130.0	130.0
42"		33.0	49.6	66.1	82.6	25.8	38.7	51.6	64.5	38.0	57.0	76.0	94.9	29.8	44.7	59.6	74.5	64.8	96.8	129.6	130.0	51.1	76.7	102.3	127.8	97.1	130.0	130.0
48"		28.9	43.4	57.8	72.3	22.6	33.8	45.1	56.4	33.2	49.8	66.5	83.1	26.1	39.1	52.1	65.2	56.7	84.7	113.4	130.0	44.7	67.1	89.5	111.9	84.9	127.4	130.0
54"		25.7	38.5	51.4	64.2	20.1	30.1	40.1	50.1	29.5	44.3	59.1	73.8	23.2	34.8	46.3	57.9	50.4	75.3	100.8	126.0	39.8	59.7	79.5	99.4	75.5	113.2	130.0
60"		23.1	34.7	46.3	57.8	-	27.1	36.1	45.1	26.6	39.9	53.2	66.5	20.9	31.3	41.7	52.1	45.4	67.8	90.7	113.4	35.8	53.7	71.6	89.5	67.9	101.9	130.0
66"		21.0	31.5	42.0	52.6	-	24.6	32.8	41.0	24.2	36.3	48.4	60.5	-	28.5	38.0	47.5	41.2	61.9	82.5	103.1	32.5	48.7	65.0	81.2	61.8	92.6	123.5
72"	-	28.9	38.5	48.2	-	22.6	30.1	37.6	22.2	33.3	44.4	55.5	-	26.1	34.8	43.5	37.8	56.7	75.6	94.5	29.8	44.7	59.5	74.4	56.6	84.9	113.2	
30"	114"	44.8	67.3	89.7	112.1	35.0	52.5	70.0	87.5	51.5	77.3	103.1	128.8	40.4	60.6	80.8	101.1	87.9	130.0	130.0	130.0	69.4	104.1	130.0	130.0	130.0	130.0	130.0
36"		37.4	56.0	74.7	93.4	29.2	43.7	58.3	72.9	42.9	64.4	85.9	107.4	33.7	50.5	67.4	84.2	73.3	109.5	130.0	130.0	57.8	86.7	115.6	130.0	109.8	130.0	130.0
42"		32.0	48.0	64.0	80.1	25.0	37.5	50.0	62.5	36.8	55.2	73.6	92.0	28.9	43.3	57.7	72.2	62.8	93.8	125.6	130.0	49.6	74.3	99.1	123.9	94.1	130.0	130.0
48"		28.0	42.0	56.0	70.1	21.9	32.8	43.7	54.7	32.2	48.3	64.4	80.5	25.3	37.9	50.5	63.2	54.9	82.1	109.9	130.0	43.4	65.1	86.7	108.4	82.3	123.5	130.0
54"		24.9	37.4	49.8	62.3	-	29.2	38.9	48.6	28.6	42.9	57.3	71.6	22.5	33.7	44.9	56.1	48.8	73.0	97.7	122.1	38.5	57.8	77.1	96.4	73.2	109.8	130.0
60"		22.4	33.6	44.8	56.0	-	26.2	35.0	43.7	25.8	38.7	51.5	64.4	20.2	30.3	40.4	50.5	44.0	65.7	87.9	109.9	34.7	52.0	69.4	86.7	65.9	98.8	130.0
66"		20.4	30.6	40.8	50.9	-	23.9	31.8	39.8	23.5	35.2	46.9	58.6	-	27.6	36.8	46.0	40.0	60.0	80.0	99.9	31.5	47.2	63.0	78.7	59.9	89.8	119.7
72"	-	28.0	37.4	46.7	-	21.9	29.2	36.5	21.5	32.3	43.0	53.8	-	25.3	33.7	42.2	36.6	55.0	73.3	91.6	28.9	43.3	57.7	72.1	54.9	82.3	109.8	
30"	120"	42.6	63.9	85.2	106.5	33.2	49.9	66.5	83.1	49.0	73.4	97.9	122.4	38.4	57.6	76.8	96.0	83.5	124.8	130.0	130.0	65.9	98.9	130.0	130.0	125.1	130.0	130.0
36"		35.5	53.2	71.0	88.7	27.7	41.6	55.4	69.3	40.8	61.2	81.6	102.0	32.0	48.0	64.0	80.0	69.6	104.0	130.0	130.0	54.9	82.4	109.9	130.0	104.3	130.0	130.0
42"		30.4	45.6	60.8	76.1	23.7	35.6	47.5	59.4	35.0	52.5	69.9	87.4	27.4	41.1	54.9	68.6	59.7	89.1	119.3	130.0	47.1	70.6	94.2	117.7	89.4	130.0	130.0
48"		26.6	39.9	53.2	66.6	20.8	31.2	41.6	52.0	30.6	45.9	61.2	76.5	24.0	36.0	48.0	60.0	52.2	78.0	104.4	130.0	41.2	61.8	82.4	103.0	78.2	117.3	130.0
54"		23.7	35.5	47.3	59.2	-	27.7	36.9	46.2	27.2	40.8	54.4	68.0	21.3	32.0	42.7	53.3	46.4	69.3	90.0	90.0	36.6	54.9	73.2	90.0	69.5	90.0	90.0
60"		21.3	31.9	42.6	53.2	-	24.9	33.2	41.6	24.5	36.8	49.0	61.3	-	28.8	38.5	48.1	41.8	62.7	83.6	90.0	32.9	49.3	65.8	82.2	62.6	90.0	90.0
66"		-	29.0	38.7	48.4	-	22.7	30.2	37.8	22.3	33.4	44.6	55.7	-	26.2	35.0	43.7	38.0	57.0	76.0	90.0	29.9	44.9	59.8	74.8	56.9	85.3	90.0
72"	-	26.6	35.5	44.4	-	20.8	27.7	34.6	20.4	30.6	40.9	51.1	-	24.0	32.1	40.1	34.8	52.2	69.6	87.0	27.4	41.1	54.8	68.5	52.1	78.2	90.0	
30"	126"	40.6	60.8	81.1	90.0	31.7	47.5	63.3	79.2	46.6	69.9	90.0	90.0	36.6	54.9	73.1	90.0	79.5	90.0	90.0	90.0	62.8	90.0	90.0	90.0	90.0	90.0	90.0
36"		33.8	50.7	67.6	84.5	26.4	39.6	52.8	66.0	38.9	58.3	77.7	90.0	30.5	45.7	61.0	76.2	66.3	90.0	90.0	90.0	52.3	78.5	90.0	90.0	90.0	90.0	90.0
42"		29.0	43.5	57.9	72.4	22.6	33.9	45.2	56.5	33.3	50.0	66.6	83.3	26.1	39.2	52.2	65.3	56.8	84.9	90.0	90.0	44.8	67.3	89.7	90.0	85.1	90.0	90.0
48"		25.4	38.0	50.7	63.4	-	29.7	39.6	49.5	29.1	43.7	58.3	72.9	22.9	34.3	45.7	57.1	49.7	74.3	90.0	90.0	39.2	58.9	78.5	90.0	74.5	90.0	90.0
54"		22.5	33.8	45.1	56.3	-	26.4	35.2	44.0	25.9	38.9	51.8	64.8	20.3	30.5	40.6	50.8	44.2	66.0	88.4	90.0	34.9	52.3	69.8	87.2	66.2	90.0	90.0
60"		20.3	30.4	40.6	50.7	-	23.7	31.7	39.6	23.3	35.0	46.7	58.4	-	27.5	36.6	45.8	39.8	59.7	79.6	90.0	31.3	47.0	62.7	78.3	59.6	89.4	90.0
72"		-	26.6	35.5	44.4	-	20.8	27.7	34.6	20.4	30.6	40.9	51.1	-	24.0	32.1	40.1	34.8	52.2	69.6	87.0	27.4	41.1	54.8	68.5	52.1	78.2	90.0
30"	132"	38.7	58.1	77.4	90.0	30.2	45.3	60.5	75.6	44.5	66.8	89.0	90.0	34.9	52.4	69.8	87.3	75.9	90.0	90.0	90.0	59.9	89.9	90.0	90.0	90.0	90.0	90.0
36"		32.3	48.4	64.5	80.7	25.2	37.8	50.4	63.0	37.1	55.6	74.2	90.0	29.1	43.6	58.2	72.7	63.3	90.0	90.0	90.0	49.9	74.9	90.0	90.0	90.0	90.0	90.0
42"		27.7	41.5	55.3	69.1	21.6	32.4	43.2	54.0	31.8	47.7	63.6	79.5	24.9	37.4	49.9	62.3	54.2	81.0	90.0	90.0	42.8	64.2	85.6	90.0	81.2	90.0	90.0
48"		24.2	36.3	48.4	60.5	-	28.3	37.8	47.2	27.8	41.7	55.6	69.5	21.8	32.7	43.6	54.5	47.5	70.9	90.0	90.0	37.5	56.2	74.9	90.0	71.1	90.0	90.0
54"		21.5	32.3	43.0	53.8	-	25.2	33.6	42.0	24.8	37.1	49.5	61.9	-	29.1	38.9	48.6	42.2	53.3	84.4	90.0	33.2	49.8	66.5	83.1	63.2	90.0	90.0
60"		-	29.0	38.7	48.4	-	22.7	30.2	37.8	22.3	33.4	44.6	55.7	-	26.2	35.0	43.7	38.0	57.0	76.0	90.0	29.9	44.9	59.8	74.8	56.9	85.3	90.0
72"		-	26.6	35.5	44.4	-	20.8	27.7	34.6	20.4	30.6	40.9	51.1	-	24.0	32.1	40.1	34.8	52.2	69.6	87.0	27.4	41.1	54.8	68.5	52.1	78.2	90.0
30"	138"	37.0	55.6	74.1	92.6	28.9	43.4	57.8	72.3	42.6	63.9	85.1	90.0	33.4	50.1	66.8	83.5	72.6	90.0	90.0	90.0	57.3	86.0	90.0	90.0	90.0	90.0	90.0
36"		30.9	46.3	61.7	77.2	24.1	36.1	48.2	60.2	35.5	53.2	71.0	88.7	27.8	41.7	55.7	69.6	60.5	90.0	90.0	90.0	47.8	71.7	90.0	90.0	90.0	90.0	90.0
42"		26.5	39.7	52.9	66.1	20.7	31.0	41.3	51.6	30.4	45.6	60.8	76.0	23.9	35.8	47.7	59.6	51.9	77.5	90.0	90.0	40.9	61.4	81.9	90.0	77.7	90.0	90.0
48"		23.1	34.7	46.3	57.9	-	27.1	36.1	45.2	26.6	39.9	53.2	66.5	20.9	31.3	41.7	52.2	45.4	67.8	90.0	90.0	35.8	53.7	71.7	89.6	68.0	90.0	90.0
54"		20.6	30.9	41.2	51.4	-	24.1	32.1	40.2	23.7	35.5	47.4	59.2	-	27.9	37.2	46.5	40.4	60.5	80.7	90.0	31.8	47.7	63.6	79.5	60.4	90.0	90.0
60"		-	27.8	37.0	46.3	-	21.7	28.9	36.1	21.3	32.0	42.6	53.3	-	25.1	33.4	41.8	36.3	54.5	72.7	90.0	28.6	42.9	57.2	71.5	54.4	81.6	90.0
72"		-	26.6	35.5	44.4	-	20.8	27.7	34.6	20.4	30.6	40.9	51.1	-	24.0	32.1	40.1	34.8	52.2	69.6	87.0	27.4	41.1	54.8	68.5	52.1	78.2	90.0
30"	144"	35.5	53.2	71.0	88.7	27.7	41.6	55.4	69.3	40.8	61.2	81.6	90.0	32.0	48.0	64.0	80.0	69.6	90.0	90.0	90.0	54.9	82.4	90.0	90.0	90.0	90.0	90.0
36"		29.6	44.4	59.2	73.9	23.1	34.6	46.2	57.7	34.0	51.0	68.0	85.0	26.7	40.0	53.3	6											

DOOR MULLION LOAD CAPACITY-PSF					
SIDELITE WIDTH INCHES	FRAME HEIGHT INCHES	JAMB 'JD1'	JAMB 'JD1'	JAMB 'JD2'	JAMB 'JD3'
		MULL 'MD1'	MULL 'MD2'	MULL 'MD3'	MULL 'MD4'
		EXT. (+) INT. (-)	EXT. (+) INT. (-)	EXT. (+) INT. (-)	EXT. (+) INT. (-)
32	86-1/2	120.0	120.0	120.0	120.0
36		120.0	120.0	120.0	120.0
42		120.0	120.0	120.0	120.0
48		120.0	120.0	120.0	120.0
54		120.0	120.0	120.0	120.0
60		120.0	120.0	120.0	120.0
32	98-1/2	112.6	120.0	120.0	120.0
36		107.1	120.0	120.0	120.0
42		99.7	120.0	120.0	120.0
48		93.3	120.0	120.0	120.0
54		87.7	120.0	116.1	120.0
32	110-1/2	79.8	120.0	118.5	120.0
36		75.8	120.0	112.6	120.0
42		70.6	113.6	104.9	120.0
48		66.1	106.3	98.2	120.0
32	120	-	-	-	90.0
36		-	-	-	90.0
42		-	-	-	90.0
48		-	-	-	85.1

MAX. DOOR WIDTH = 45-1/2" (X)
87-1/2" (XX)
MAX. CL TO CL DIM. = 43-3/4" (X)
85-3/4" (XX)

MAX. DOOR WIDTH = 49-3/4" (X)
97-3/4" (XX)
MAX. CL TO CL DIM. = 48" (X)
96" (XX)

DOOR MULLION LOAD CAPACITY-PSF					
SIDELITE WIDTH INCHES	FRAME HEIGHT INCHES	JAMB 'JD1'	JAMB 'JD1'	JAMB 'JD2'	JAMB 'JD3'
		MULL 'MD1'	MULL 'MD2'	MULL 'MD3'	MULL 'MD4'
		EXT. (+) INT. (-)	EXT. (+) INT. (-)	EXT. (+) INT. (-)	EXT. (+) INT. (-)
32	98-1/2	90.0	90.0	90.0	90.0
36		90.0	90.0	90.0	90.0
42		90.0	90.0	90.0	90.0
48		90.0	90.0	90.0	90.0
54		87.7	90.0	90.0	90.0
32	110-1/2	79.8	90.0	90.0	90.0
36		75.8	90.0	90.0	90.0
42		70.6	90.0	90.0	90.0
48		66.1	90.0	90.0	90.0
32	114	72.6	90.0	90.0	90.0
36		69.1	90.0	90.0	90.0
42		64.3	90.0	90.0	90.0
48	120	60.2	90.0	90.0	90.0
32		62.3	90.0	90.0	90.0
36		59.2	90.0	90.0	90.0
42	144	55.2	88.7	89.1	90.0
48		51.6	83.0	83.4	90.0
32		-	-	-	90.0
36	-	-	-	89.8	
42	-	-	-	83.6	
48	-	-	-	78.3	

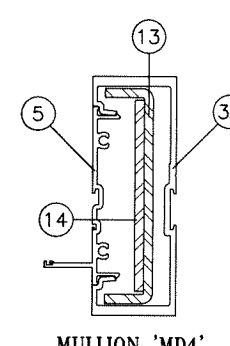
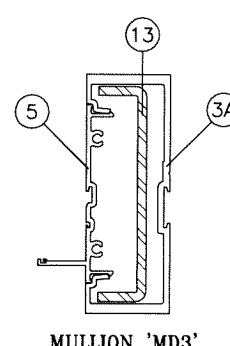
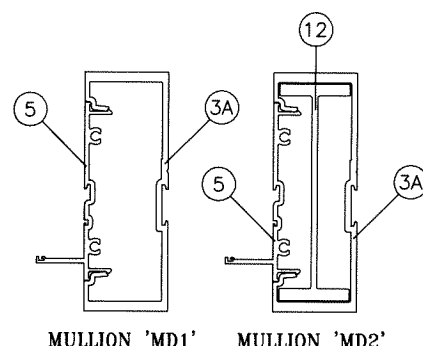
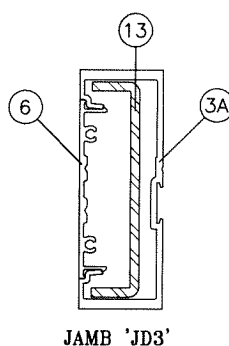
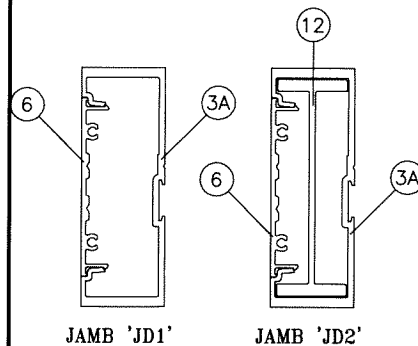
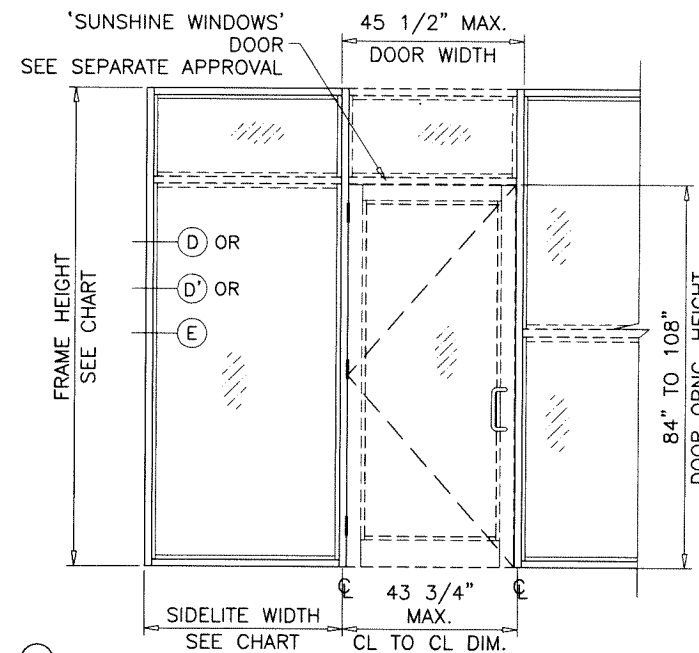
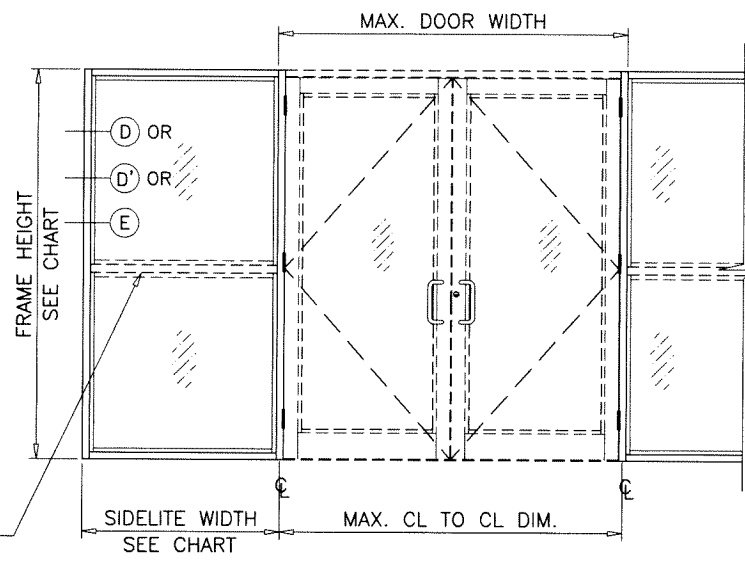
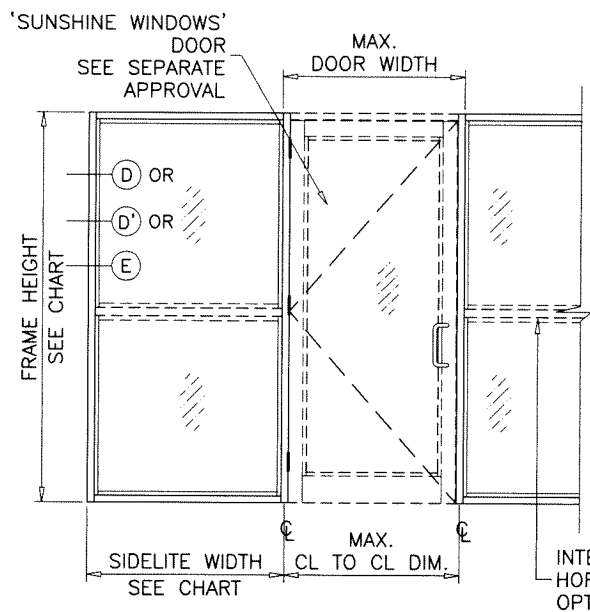

Ix IN^4	Sx IN^3	Ix IN^4	Sx IN^3
6.570	2.7226	10.6577	3.8057

ALUMINUM	Ix IN^4	Sx IN^3
	6.570	2.7226
STEEL	Ix IN^4	Sx IN^3
	2.7506	1.2224
TOTAL	Ix ALUM + Ix STL X 2.9	14.5467

Ix IN^4	Sx IN^3	Ix IN^4	Sx IN^3
6.7195	2.6757	10.8072	4.4788

ALUMINUM	Ix IN^4	Sx IN^3
	6.7195	2.6757
STEEL	Ix IN^4	Sx IN^3
	2.7506	1.224
TOTAL	Ix ALUM + Ix STL X 2.9	14.6962

ALUMINUM	Ix IN^4	Sx IN^3
	6.7195	2.6757
STEEL	Ix IN^4	Sx IN^3
	3.7533	1.668
TOTAL	Ix ALUM + Ix STL X 2.9	17.6041

Sealed: 7/26/2023

FL #37315.1

DOOR-WINDOW WALL TRANSITION MULLION

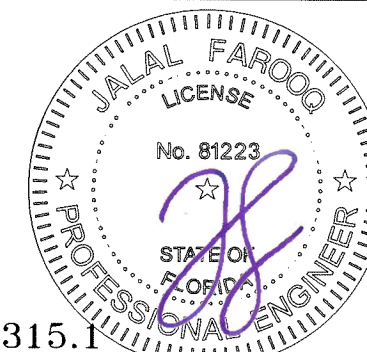

af c
AL-FAROOQ CORPORATION
ENGINEERS & PRODUCT DEVELOPMENT
9360 SUNSET DRIVE, SUITE 220
MIAMI, FLORIDA 33173 (C.A.N. 3538)
TEL. (305) 264-8100 FAX. (305) 262-6978
STORE\21-01F-SW

SERIES 8000 ALUM WINDOW WALL SYSTEM (L.M.I.)
Sunshine Windows Manufacturing, Inc.
1785 West 33rd Place
Hialeah, FL 33012
Tel. (305) 364-9952 Fax. (305) 828-5118

no	date	by	description

date: 01-07-21
scale: -
dr. by: TARIQ
chk. by:

drawing no.
21-01F
sheet 6 of 12

DOOR MULLION LOAD CAPACITY - PSF							
NOMINAL DIMS.				JAMB 'JD1'	JAMB 'JD1'	JAMB 'JD2'	JAMB 'JD3'
WIDTH (W1)	WIDTH (W2)	FRAME HEIGHT	DOOR HEIGHT	MULL 'MD1'	MULL 'MD2'	MULL 'MD3'	MULL 'MD4'
INCHES	INCHES	INCHES	INCHES	EXT.(+) INT.(-)	EXT.(+) INT.(-)	EXT.(+) INT.(-)	EXT.(+) INT.(-)
85-3/4	30	96	84	90.0	90.0	90.0	90.0
	36			90.0	90.0	90.0	90.0
	42			90.0	90.0	90.0	90.0
	48			90.0	90.0	90.0	90.0
	54			90.0	90.0	90.0	90.0
	60			85.7	90.0	90.0	90.0
	30	102		90.0	90.0	90.0	90.0
	36			86.9	90.0	90.0	90.0
	42			81.5	90.0	90.0	90.0
	48			76.7	90.0	90.0	90.0
	54			72.5	90.0	89.0	90.0
	60			74.2	90.0	90.0	90.0
	30	108		69.5	90.0	89.1	90.0
	36			65.4	90.0	84.4	90.0
	42			61.7	90.0	80.2	90.0
	48			60.2	90.0	81.7	90.0
	54			56.6	90.0	77.4	90.0
	60			53.3	85.8	73.4	87.8
	30	114		73.4	87.8	73.4	87.8
	36			50.5	81.2	69.9	83.5
	42			49.7	80.0	71.9	85.9
	48			46.8	75.3	68.1	81.5
	54			44.2	71.2	64.8	77.4
	60			41.9	67.5	61.7	73.8
30	120	90.0	90.0	90.0	90.0		
36		90.0	90.0	90.0	90.0		
42		86.6	90.0	90.0	90.0		
48		81.2	90.0	90.0	90.0		
54		76.5	90.0	90.0	90.0		
60		79.3	90.0	90.0	90.0		
30	108	74.0	90.0	90.0	90.0		
36		69.3	90.0	88.9	90.0		
42		65.2	90.0	84.3	90.0		
48		63.9	90.0	85.6	90.0		
54		59.9	90.0	80.8	90.0		
60		56.3	90.0	76.5	90.0		
30	114	53.1	85.4	72.7	86.9		
36		52.4	84.2	74.5	89.1		
42		49.2	79.1	70.5	84.3		
48		46.3	74.5	66.9	80.0		
54		43.8	70.5	63.6	76.1		
60		43.8	70.5	63.6	76.1		

DOOR MULLION LOAD CAPACITY - PSF							
NOMINAL DIMS.				JAMB 'JD1'	JAMB 'JD1'	JAMB 'JD2'	JAMB 'JD3'
WIDTH (W1)	WIDTH (W2)	FRAME HEIGHT	DOOR HEIGHT	MULL 'MD1'	MULL 'MD2'	MULL 'MD3'	MULL 'MD4'
INCHES	INCHES	INCHES	INCHES	EXT.(+) INT.(-)	EXT.(+) INT.(-)	EXT.(+) INT.(-)	EXT.(+) INT.(-)
85-3/4	30	108	96	84.6	90.0	90.0	90.0
	36			78.6	90.0	90.0	90.0
	42			73.4	90.0	90.0	90.0
	48			68.8	90.0	89.7	90.0
	54			68.2	90.0	90.0	90.0
	60			63.5	90.0	85.3	90.0
	30	114		59.5	90.0	80.6	90.0
	36			56.0	90.0	76.3	90.0
	42			55.5	89.3	78.0	90.0
	48			51.9	83.5	73.6	88.0
	54			48.8	78.5	69.7	83.3
	60			46.0	74.0	66.2	79.1
30	120	72.4	90.0	90.0	90.0		
36		67.2	90.0	90.0	90.0		
42		62.7	90.0	85.9	90.0		
48		58.8	90.0	81.1	90.0		
54		59.0	90.0	82.6	90.0		
60		55.0	88.4	77.7	90.0		
30	114	51.5	82.8	73.3	87.7		
36		48.4	77.8	69.4	83.0		
42		63.7	90.0	90.0	90.0		
48		59.0	90.0	85.7	90.0		
54		55.0	88.4	80.4	90.0		
60		51.5	82.8	75.7	90.0		

INTERPOLATION BETWEEN WIDTHS OR HEIGHTS ALLOWED.

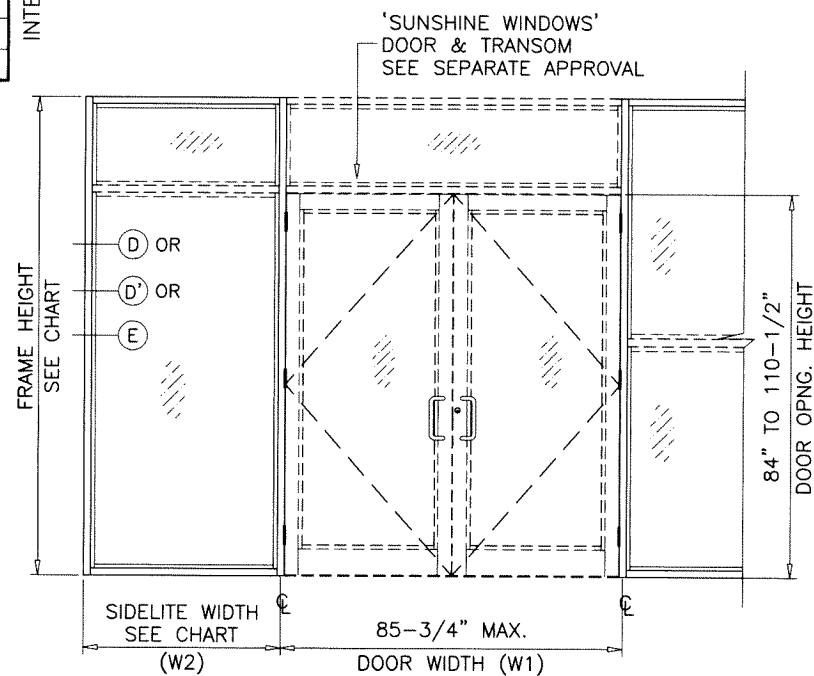

DOOR-WINDOWALL TRANSITION MULLION

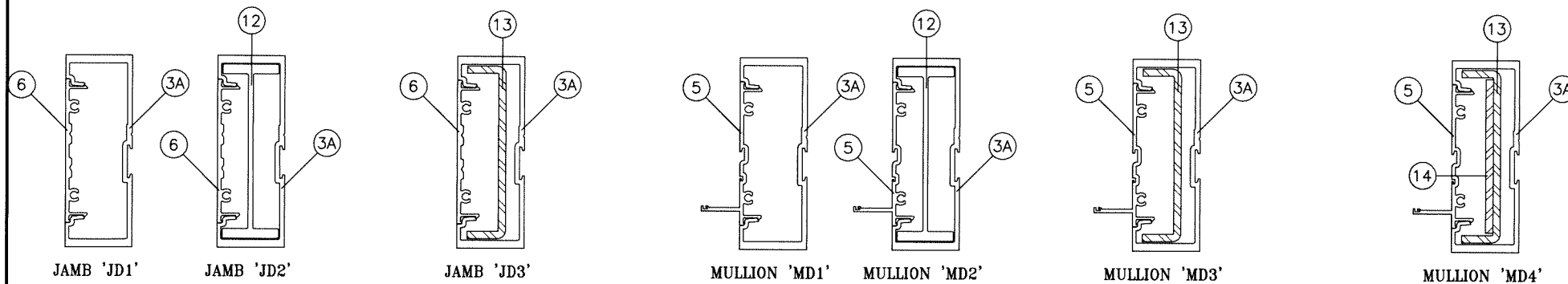

Ix IN ⁴	Sx IN ³	Ix IN ⁴	Sx IN ³	Ix IN ⁴	Sx IN ³	Ix IN ⁴	Sx IN ³	Ix IN ⁴	Sx IN ³	Ix IN ⁴	Sx IN ³	Ix IN ⁴	Sx IN ³
6.570	2.7226	10.6577	3.8057	6.570	2.7226	6.7195	2.6757	10.8072	4.4788	6.7195	2.6757	6.7195	2.6757
ALUMINUM		STEEL		TOTAL		ALUMINUM		STEEL		TOTAL		ALUMINUM	
				Ix ALUM + Ix STL X 2.9						Ix ALUM + Ix STL X 2.9			
				14.5467						14.6962			
												17.6041	

Sealed: 7/26/2023

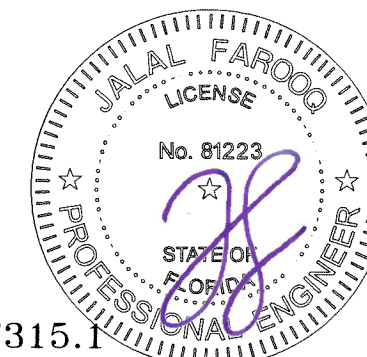

FL #37315.1

af c
AL-FAROOQ CORPORATION
 ENGINEERS & PRODUCT DEVELOPMENT
 9360 SUNSET DRIVE, SUITE 220
 MIAMI, FLORIDA 33173 (C.A.N. 3538)
 TEL. (305) 264-8100 FAX. (305) 262-6978
 STORE \21-01F-SW

SERIES 8000 ALUM WINDOW WALL SYSTEM (L.M.I.)
Sunshine Windows Manufacturing, Inc.
 1785 West 33rd Place
 Hialeah, FL 33012
 Tel. (305) 364-9952 Fax. (305) 828-5118

no	date	by	description

date: 01-07-21
 scale: -
 dr. by: TARIQ
 chk. by:

drawing no.
21-01F
 sheet 6.1 of 12

DOOR MULLION HEAD ANCHOR LOAD CAPACITY - PSF						
NOMINAL DIMS.				'C4'	'C5'	'C6'
WIDTH (W1) INCHES	WIDTH (W2) INCHES	FRAME HEIGHT INCHES	DOOR HEIGHT INCHES	EXT.(+) INT.(-)	EXT.(+) INT.(-)	EXT.(+) INT.(-)
85-3/4	30	96	84	89.6	90.0	90.0
				85.0	90.0	90.0
				80.8	90.0	90.0
				77.0	90.0	90.0
				73.6	90.0	90.0
				70.4	88.0	90.0
	36	102	84	86.0	90.0	90.0
				81.5	90.0	90.0
				77.4	90.0	90.0
				73.8	90.0	90.0
				70.4	88.0	90.0
				82.7	90.0	90.0
	42	108	84	78.3	90.0	90.0
				74.3	90.0	90.0
				70.8	88.4	90.0
				79.7	90.0	90.0
				75.4	90.0	90.0
				71.5	89.4	90.0
	48	114	84	68.0	85.0	90.0
				76.9	90.0	90.0
				72.6	90.0	90.0
				68.9	86.1	90.0
				65.4	81.8	90.0
				84.1	90.0	90.0
85-3/4	30	102	90	79.7	90.0	90.0
				75.8	90.0	90.0
				72.3	90.0	90.0
				69.1	86.4	90.0
	36	108	90	80.9	90.0	90.0
				76.7	90.0	90.0
				72.9	90.0	90.0
				69.4	86.8	90.0
	42	114	90	78.0	90.0	90.0
				73.9	90.0	90.0
				70.1	87.7	90.0
				66.8	83.5	90.0
48	120	90	75.3	90.0	90.0	
			71.2	89.1	90.0	
			67.6	84.5	90.0	
			64.3	80.4	90.0	

DOOR MULLION HEAD ANCHOR LOAD CAPACITY - PSF						
NOMINAL DIMS.				'C4'	'C5'	'C6'
WIDTH (W1) INCHES	WIDTH (W2) INCHES	FRAME HEIGHT INCHES	DOOR HEIGHT INCHES	EXT.(+) INT.(-)	EXT.(+) INT.(-)	EXT.(+) INT.(-)
85-3/4	30	108	96	79.2	90.0	90.0
				75.1	90.0	90.0
				71.5	89.3	90.0
				68.1	85.2	90.0
	36	114	96	76.4	90.0	90.0
				72.4	90.0	90.0
				68.8	86.0	90.0
				65.6	82.0	90.0
	42	120	96	73.8	90.0	90.0
				69.9	87.4	90.0
				66.4	83.0	90.0
				63.2	79.0	90.0
85-3/4	30	114	102	74.9	90.0	90.0
				71.0	88.8	90.0
				67.6	84.5	90.0
				64.4	80.5	90.0
	36	120	102	72.4	90.0	90.0
				68.6	85.7	90.0
				65.2	81.5	90.0
				62.1	77.7	90.0
	42	120	110-1/2	70.4	88.0	90.0
				66.8	83.5	90.0
				63.6	79.5	90.0
				60.7	75.9	90.0

INTERPOLATION BETWEEN WIDTHS OR HEIGHTS ALLOWED.

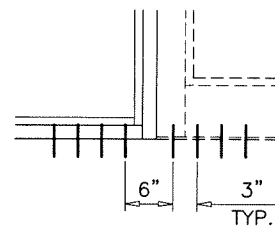
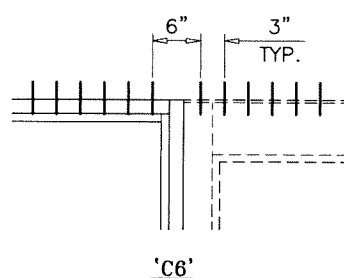
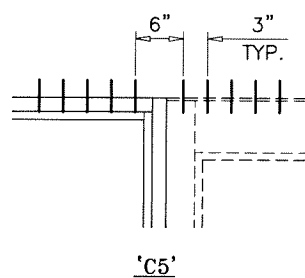
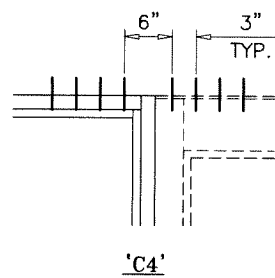
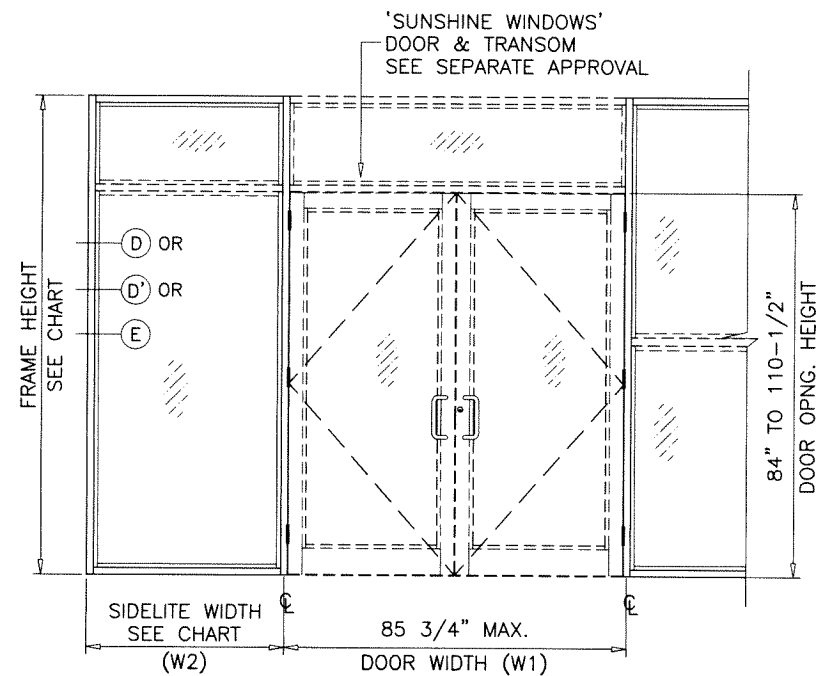

'C4' AT SILL ALL CASES

ANCHORS TYPES: SEE SHEET 8 FOR DESCRIPTION

C4 = (4) ANCHORS TYPE 'C' AT EACH SIDE OF DOOR MULLION

C5 = (5) ANCHORS TYPE 'C' AT EACH SIDE OF DOOR MULLION

C6 = (6) ANCHORS TYPE 'C' AT EACH SIDE OF DOOR MULLION

ALL OTHER ANCHORS TO BE SPACED AS PER ELEVATION.

TRANSITION MULLION ANCHORS

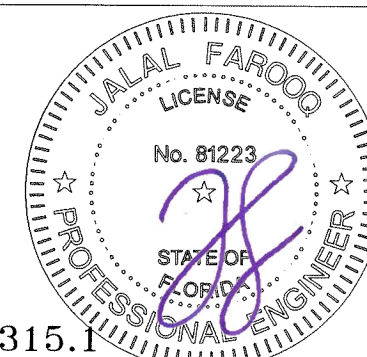

Sealed: 7/26/2023

FL #37315.1

af c
AL-FAROOQ CORPORATION
 ENGINEERS & PRODUCT DEVELOPMENT
 9360 SUNSET DRIVE, SUITE 220
 MIAMI, FLORIDA 33173 (C.A.N. 3538)
 TEL. (305) 264-8100 FAX. (305) 262-6978
 STORE \21-01F-SW

SERIES 8000 ALUM WINDOW WALL SYSTEM (L.M.I.)
Sunshine Windows Manufacturing, Inc.
 1785 West 33rd Place
 Hialeah, FL. 33012
 Tel. (305) 364-9952 Fax. (305) 828-5118

no	date	by	description

date: 01-07-21	scale: -	dr. by: TARIQ	chk. by:
----------------	----------	---------------	----------

drawing no.
21-01F
 sheet 7 of 12

DOOR MULLION HEAD ANCHOR LOAD CAPACITY - PSF							
NOMINAL DIMS.				'C4'	'C5'	'C6'	
WIDTH (W1) INCHES	WIDTH (W2) INCHES	FRAME HEIGHT INCHES	DOOR HEIGHT INCHES	EXT.(+) INT.(-)	EXT.(+) INT.(-)	EXT.(+) INT.(-)	
96	30	96	84	82.4	90.0	90.0	
	36			78.5	90.0	90.0	
	42			74.9	90.0	90.0	
	48			71.7	89.6	90.0	
	54			68.7	85.8	90.0	
	60			65.9	82.4	90.0	
	30	102	79.2	90.0	90.0		
	36		75.3	90.0	90.0		
	42		71.8	89.8	90.0		
	48		68.7	85.8	90.0		
	54		65.8	82.2	90.0		
	30		108	76.2	90.0	90.0	
	36	72.4		90.0	90.0		
	42	69.0		86.3	90.0		
	48	65.9		82.4	90.0		
	30	114		73.4	90.0	90.0	
	36			69.8	87.2	90.0	
	42		66.4	83.0	90.0		
	48		63.4	79.2	90.0		
	30		120	70.9	88.6	90.0	
	36			67.3	84.1	90.0	
	42	64.0		80.0	90.0		
	48	61.0		76.3	90.0		
	96	30		102	90	77.3	90.0
36		73.7				90.0	90.0
42		70.3	87.9			90.0	
48		67.3	84.1			90.0	
54		64.5	80.6			90.0	
30		108	74.5			90.0	90.0
36			70.9	88.6	90.0		
42			67.6	84.5	90.0		
48			64.6	80.8	90.0		
30			114	71.8	89.8	90.0	
36				68.3	85.4	90.0	
42		65.1		81.4	90.0		
48		62.2		77.7	90.0		
30		120		69.4	86.7	90.0	
36				65.9	82.4	90.0	
42			62.8	78.5	90.0		
48			59.9	74.9	89.9		

DOOR MULLION HEAD ANCHOR LOAD CAPACITY - PSF							
NOMINAL DIMS.				'C4'	'C5'	'C6'	
WIDTH (W1) INCHES	WIDTH (W2) INCHES	FRAME HEIGHT INCHES	DOOR HEIGHT INCHES	EXT.(+) INT.(-)	EXT.(+) INT.(-)	EXT.(+) INT.(-)	
96	30	108	96	72.8	90.0	90.0	
	36			69.4	86.7	90.0	
	42			66.3	82.8	90.0	
	48			63.4	79.2	90.0	
	30	114	70.3	87.9	90.0		
	36		66.9	83.7	90.0		
	42		63.8	79.8	90.0		
	48		61.0	76.3	90.0		
	30	120	68.0	84.9	90.0		
	36		64.6	80.8	90.0		
	42		61.6	77.0	90.0		
	48		58.9	73.6	88.3		
96	30	114	102	68.8	86.1	90.0	
	36			65.6	82.0	90.0	
	42			62.6	78.3	90.0	
	48			59.9	74.9	89.9	
	30	120	66.6	83.2	90.0		
	36		63.4	79.2	90.0		
	42		60.5	75.6	90.0		
	48		57.8	72.3	86.7		
	96	30	120	110-1/2	64.7	80.9	90.0
		36			61.7	77.1	90.0
		42			58.9	73.7	88.4
		48			56.4	70.5	84.6
96	30	144	108	57.8	72.3	86.7	
	36			54.9	68.7	82.4	
	42			52.3	65.4	78.5	
	48			49.9	62.4	74.9	

INTERPOLATION BETWEEN WIDTHS OR HEIGHTS ALLOWED.

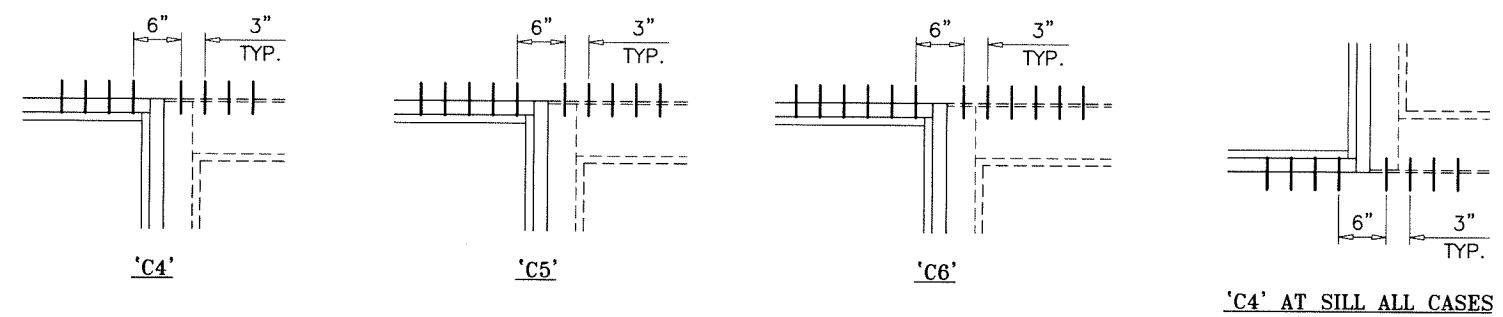
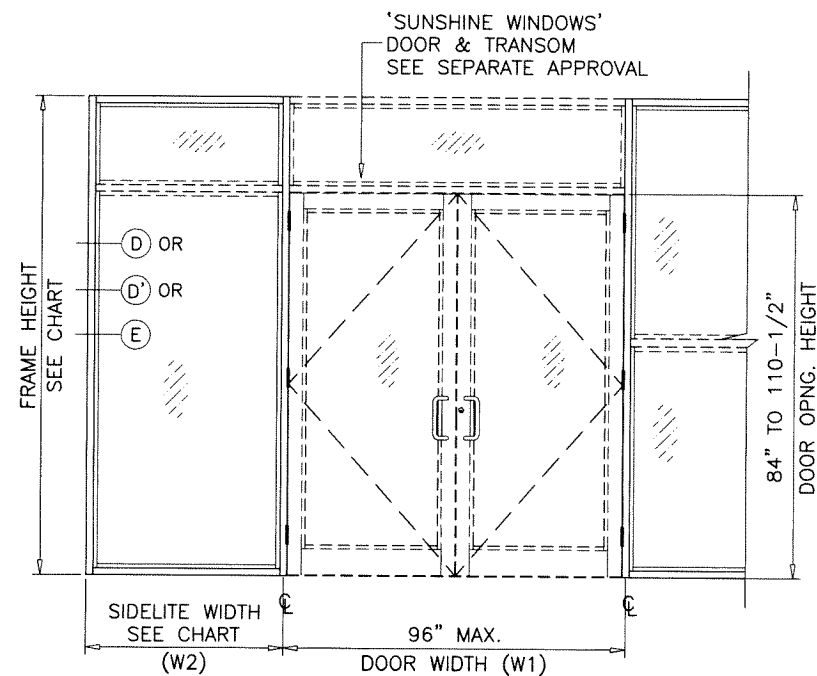

ANCHORS TYPES: SEE SHEET 8 FOR DESCRIPTION
 C4 = (4) ANCHORS TYPE 'C' AT EACH SIDE OF DOOR MULLION
 C5 = (5) ANCHORS TYPE 'C' AT EACH SIDE OF DOOR MULLION
 C6 = (6) ANCHORS TYPE 'C' AT EACH SIDE OF DOOR MULLION
 ALL OTHER ANCHORS TO BE SPACED AS PER ELEVATION.

TRANSITION MULLION ANCHORS

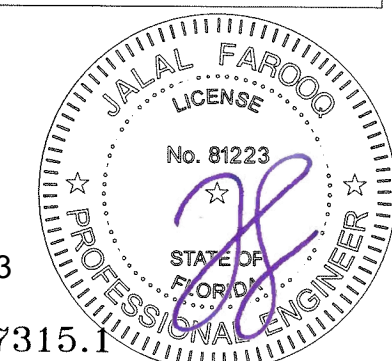

Sealed: 7/26/2023

FL #37315.1

af c
AL-FAROOQ CORPORATION
 ENGINEERS & PRODUCT DEVELOPMENT
 9360 SUNSET DRIVE, SUITE 220
 MIAMI, FLORIDA 33173 (C.A.N. 3538)
 TEL. (305) 264-8100 FAX. (305) 262-6978
 STORE \21-01F-SW

SERIES 8000 ALUM WINDOW WALL SYSTEM (L.M.I.)
Sunshine Windows Manufacturing, Inc.
 1785 West 33rd Place
 Hialeah, FL. 33012
 Tel. (305) 364-9952 Fax. (305) 828-5118

no	date	by	description

date: 01-07-21
 scale: -
 dr. by: TARIQ
 chk. by:
 drawing no. 21-01F
 sheet 7.1 of 12

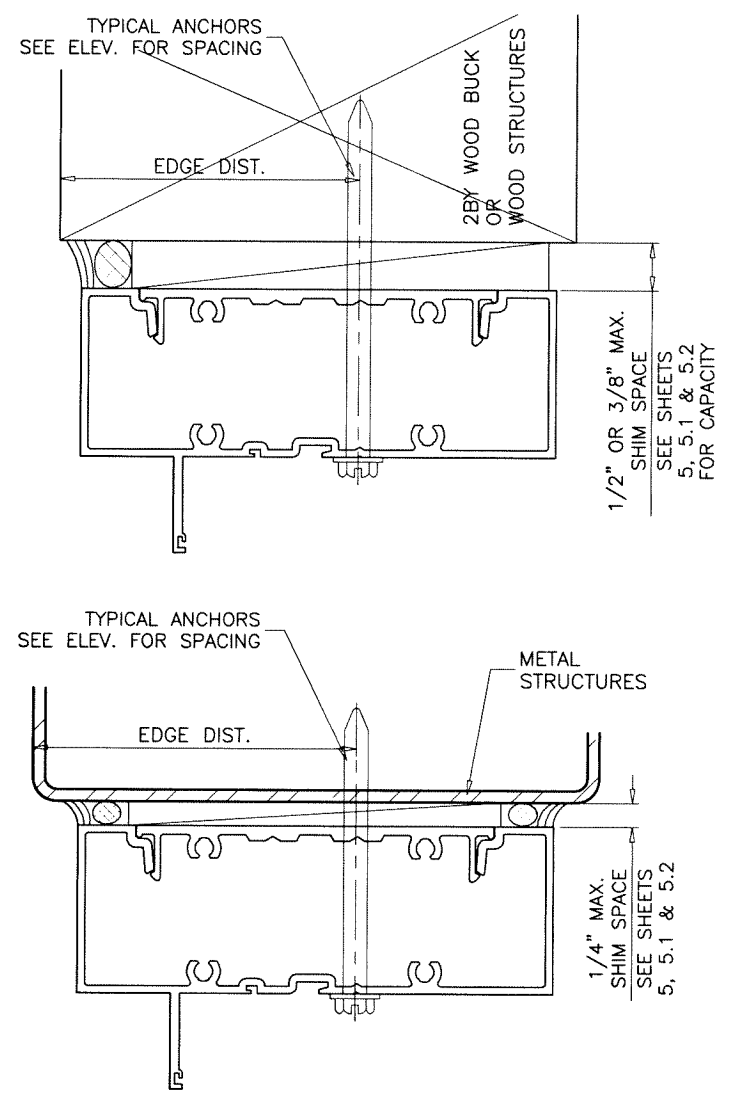
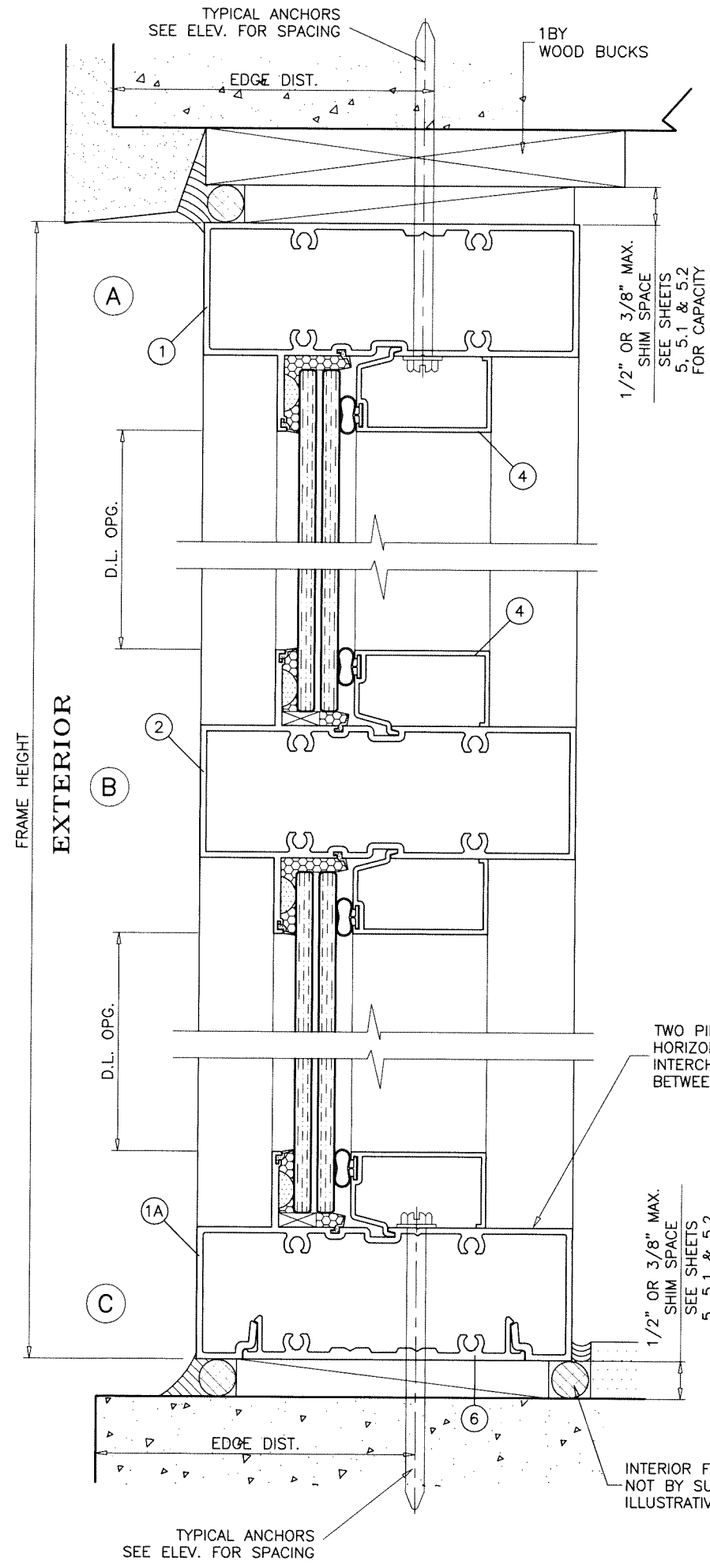

TYPICAL ANCHORS: SEE ELEV. FOR SPACING

TYPE 'A' - 1/4" DIA. ULTRACON+ BY 'DEWALT' (Fu=164 KSI, Fy=148 KSI)
 INTO 2BY WOOD BUCKS OR WOOD STRUCTURES WITH 1-1/2" MIN. PENETRATION INTO WOOD
 THRU 1BY WOOD BUCKS INTO CONCRETE WITH 1-1/4" MIN. EMBED INTO CONCRETE
 DIRECTLY INTO CONCRETE WITH 1-1/4" MIN. EMBED INTO CONC.

ANCHOR EDGE DISTANCES

INTO CONCRETE AND MASONRY = 2-1/2" MIN.
 INTO WOOD STRUCTURE = 1" MIN.

TYPE 'B' - 1/4" DIA. KWIK-CON II+ BY 'HILTI' (Fu=138 KSI, Fy=137 KSI)
 INTO 2BY WOOD BUCKS OR WOOD STRUCTURES WITH 1-1/2" MIN. PENETRATION INTO WOOD
 THRU 1BY WOOD BUCKS INTO CONCRETE WITH 1-1/4" MIN. EMBED INTO CONCRETE
 DIRECTLY INTO CONCRETE WITH 1-1/4" MIN. EMBED INTO CONC.

ANCHOR EDGE DISTANCES

INTO CONCRETE AND MASONRY = 3" MIN.
 INTO WOOD STRUCTURE = 1" MIN.

TYPE 'C' - 5/16" DIA ULTRACON BY 'DEWALT' (Fu=177 KSI, Fy=155 KSI)
 INTO 2BY WOOD BUCKS OR WOOD STRUCTURES WITH 1-1/2" MIN. PENETRATION INTO WOOD
 THRU 1BY WOOD BUCKS INTO CONCRETE WITH 1-1/4" MIN. EMBED INTO CONCRETE
 DIRECTLY INTO CONCRETE WITH 1-1/4" MIN. EMBED INTO CONC.

ANCHOR EDGE DISTANCES

INTO CONCRETE AND MASONRY = 3" MIN.
 INTO WOOD STRUCTURE = 1-1/4" MIN.

TYPE 'D' - 1/4" DIA. TEKS OR SELF DRILLING SCREWS ST/ST (GRADE 5 CRS)
 INTO METAL STRUCTURES (3) THREADS MIN. PENETRATION BEYOND SUBSTRATE
 ALUMINUM: 1/8" THK. MIN. (6063-T5 MIN.)
 STEEL: 1/8" THK. MIN. (Fy = 36 KSI MIN.)
 (STEEL IN CONTACT WITH ALUMINUM TO BE PLATED OR PAINTED)

ANCHOR EDGE DISTANCES

INTO METAL STRUCTURE = 1/2" MIN.

WOOD AT HEAD, SILL OR JAMBS SG = 0.55 MIN.
 CONCRETE AT HEAD, SILL OR JAMBS f'c = 3000 PSI MIN.
 C-90 HOLLOW/FILLED BLOCK AT JAMBS f'm = 2000 PSI MIN.

SEALANTS:

ALL FRAME CORNERS, JOINTS, MULLION SEAMS AND PERIMETER OF GLAZING BEAD TO FRAME SEALED WITH SILICONE SEALANT.

WOOD BUCKS AND METAL STRUCTURES NOT BY 'SUNSHINE WDW.'
 MUST SUPPORT LOADS IMPOSED BY GLAZING SYSTEM AND TRANSFER THEM TO THE BUILDING STRUCTURE.

Sealed: 7/26/2023

FL #37315.1

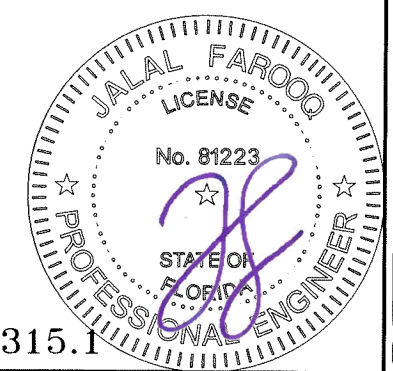

af c
AL-FAROOQ CORPORATION
 ENGINEERS & PRODUCT DEVELOPMENT
 9360 SUNSET DRIVE, SUITE 220
 MIAMI, FLORIDA 33173 (C.A.N. 3538)
 TEL. (305) 264-8100 FAX. (305) 262-6978
 STORE 21-01F-SW

SERIES 8000 ALUM WINDOW WALL SYSTEM (L.M.I.)
Sunshine Windows Manufacturing, Inc.
 1785 West 33rd Place
 Hialeah, FL 33012
 Tel. (305) 364-9952 Fax. (305) 828-5118

no	date	by description

date: 01-07-21	scale: 1/2" = 1"	dr. by: TARIQ	chk. by:
----------------	------------------	---------------	----------

drawing no.
21-01F
 sheet 8 of 12

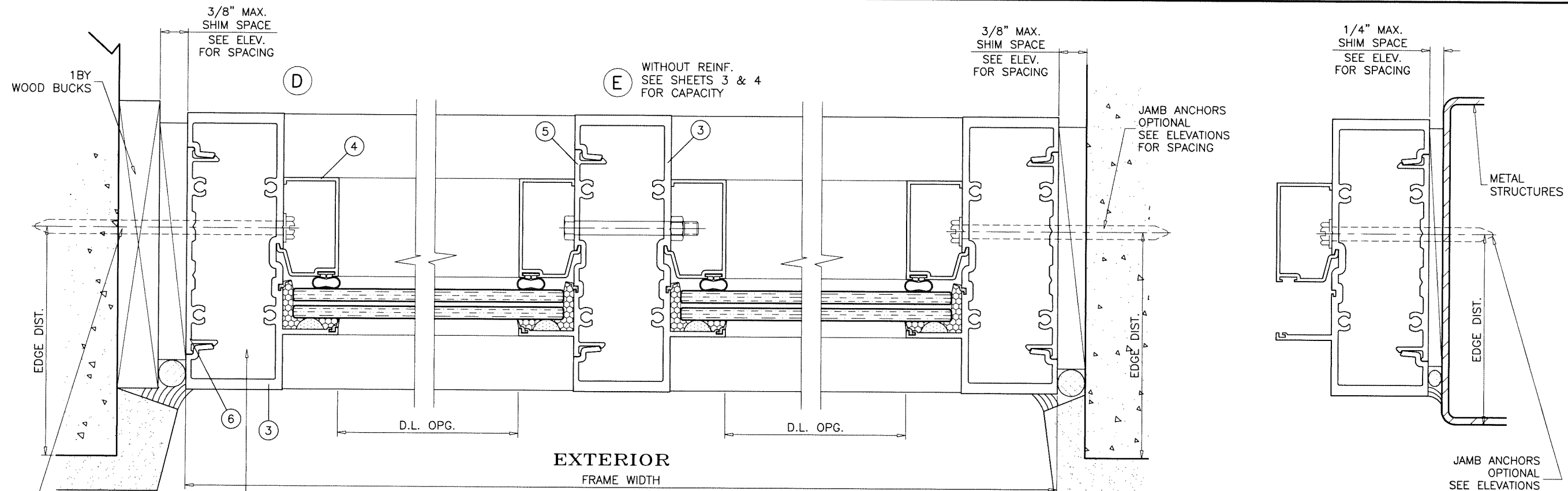

JAMB ANCHORS OPTIONAL SEE ELEVATIONS FOR SPACING

ANCHORED JAMBS DO NOT REQUIRE REINFORCING

UNANCHORED JAMBS MAY REQUIRE REINFORCING SEE CHARTS



D' ALUM REINF. SEE SHEETS 3 & 4 FOR CAPACITY

1/4" DIA. BOLTS WITH NUTS AT 6" FROM ENDS AND 18-1/2" O.C. MAX.

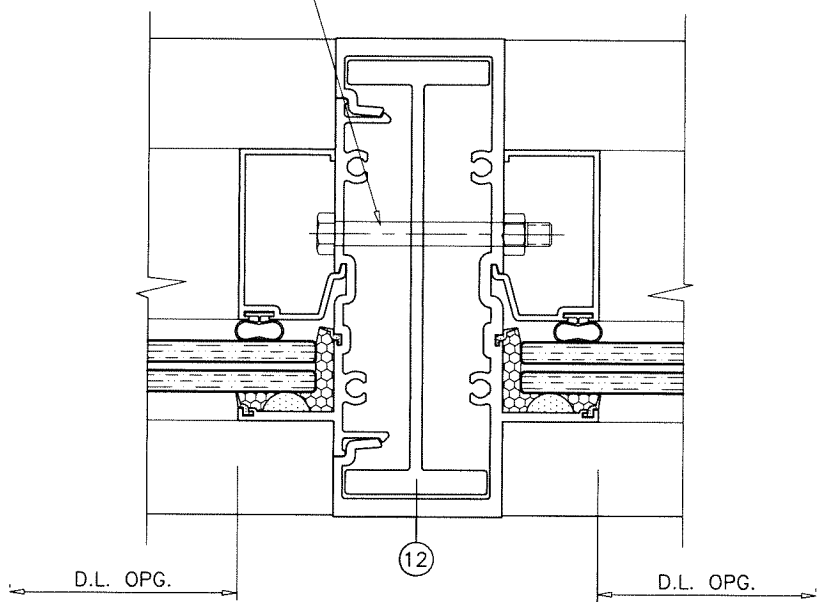

E ALUM REINF. SEE SHEETS 3 & 4 FOR CAPACITY

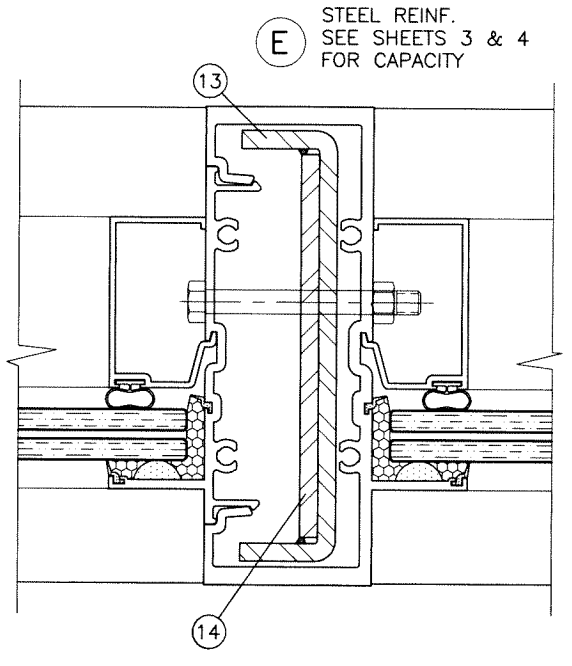

E STEEL REINF. SEE SHEETS 3 & 4 FOR CAPACITY

FINISHES NOT BY 'SUNSHINE WINDOWS' ILLUSTRATIVE ONLY

Sealed: 7/26/2023

FL #37315.1

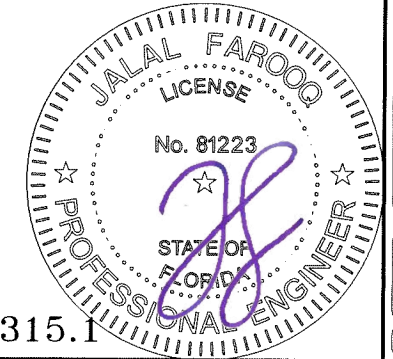

af c

AL-FAROOQ CORPORATION
ENGINEERS & PRODUCT DEVELOPMENT
9360 SUNSET DRIVE, SUITE 220
MIAMI, FLORIDA 33173 (C.A.N. 3538)
TEL. (305) 264-8100 FAX. (305) 262-6978
STORE 21-01F-SW

SERIES 8000 ALUM WINDOW WALL SYSTEM (L.M.I.)

Sunshine Windows Manufacturing, Inc.
1785 West 33rd Place
Hialeah, FL 33012
Tel. (305) 364-9952 Fax. (305) 828-5118

no	date	by	description

date: 01-07-21
scale: 1/2" = 1"
dr. by: TARIQ
chk. by:

drawing no.
21-01F
sheet 9 of 12

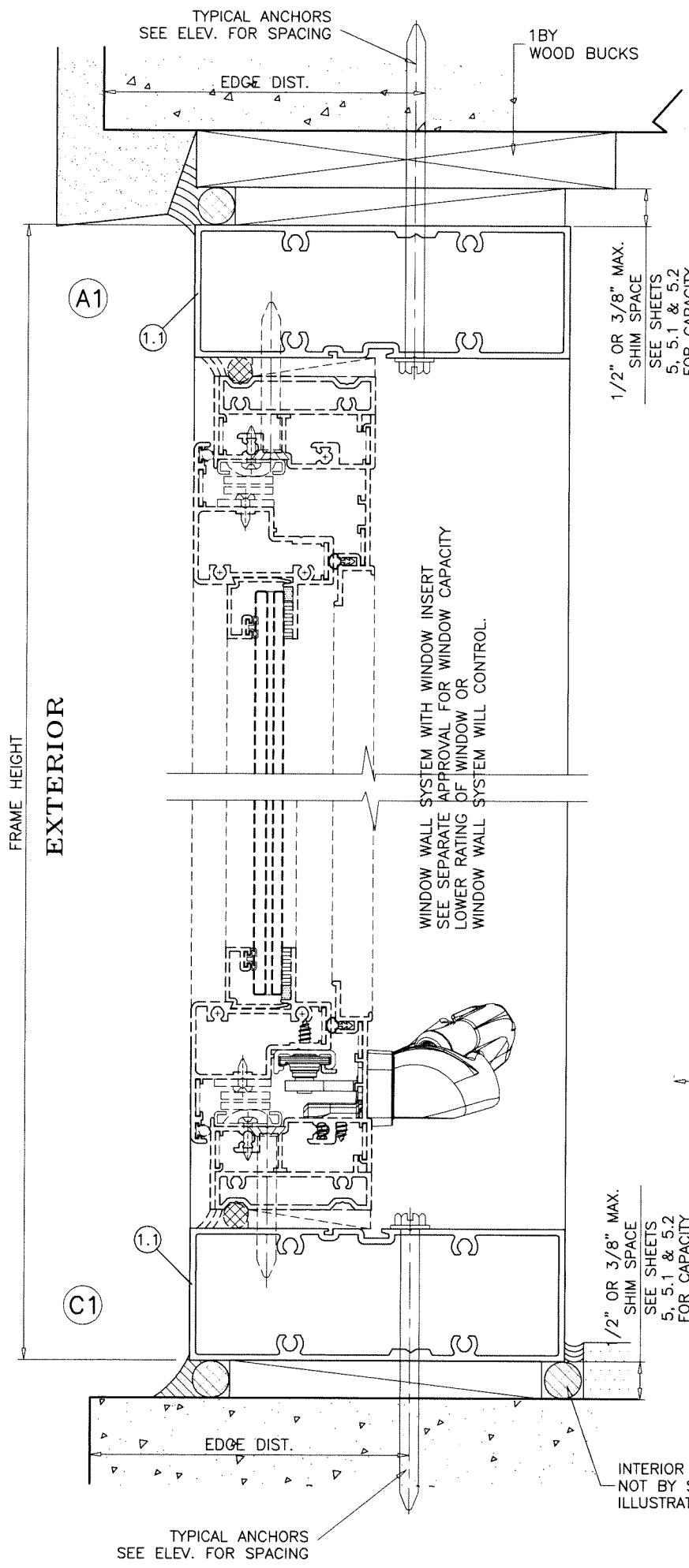

WINDOW WALL SYSTEM WITH WINDOW INSERT
 SEE SEPARATE APPROVAL FOR WINDOW CAPACITY
 LOWER RATING OF WINDOW OR
 WINDOW WALL SYSTEM WILL CONTROL.

1/2" OR 3/8" MAX.
 SHIM SPACE
 SEE SHEETS
 5, 5.1 & 5.2
 FOR CAPACITY

1/2" OR 3/8" MAX.
 SHIM SPACE
 SEE SHEETS
 5, 5.1 & 5.2
 FOR CAPACITY

INTERIOR FINISHES
 NOT BY SUNSHINE WINDOWS
 ILLUSTRATIVE ONLY

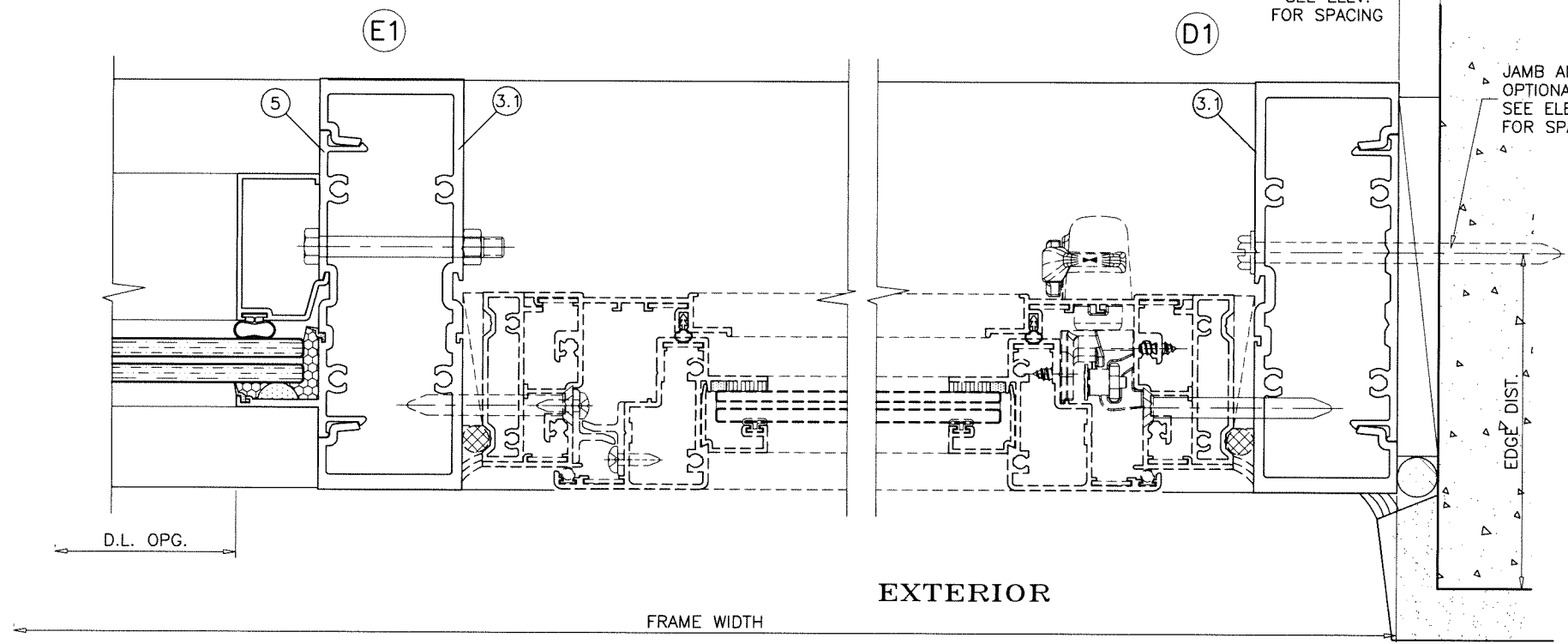

EXTERIOR

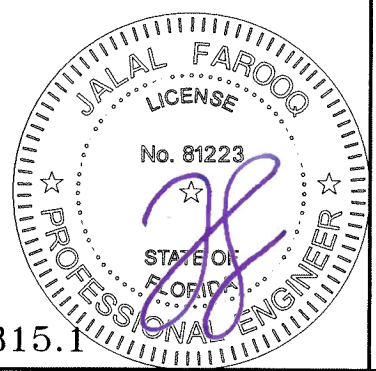

Sealed: 7/26/2023

FL #37315.1

af c

AL-FAROOQ CORPORATION
 ENGINEERS & PRODUCT DEVELOPMENT
 9360 SUNSET DRIVE, SUITE 220
 MIAMI, FLORIDA 33173 (C.A.N. 3538)
 TEL. (305) 264-8100 FAX. (305) 262-6978
 STORE 21-01F-SW

SERIES 8000 ALUM WINDOW WALL SYSTEM (L.M.I.)

Sunshine Windows Manufacturing, Inc.
 1785 West 33rd Place
 Hialeah, FL 33012
 Tel. (305) 364-9952 Fax. (305) 828-5118

no	date	by	description

date: 01-07-21
 scale: 1/2" = 1"
 dr. by: TARIQ
 chk. by:

drawing no.
21-01F
 sheet 10.1 of 12

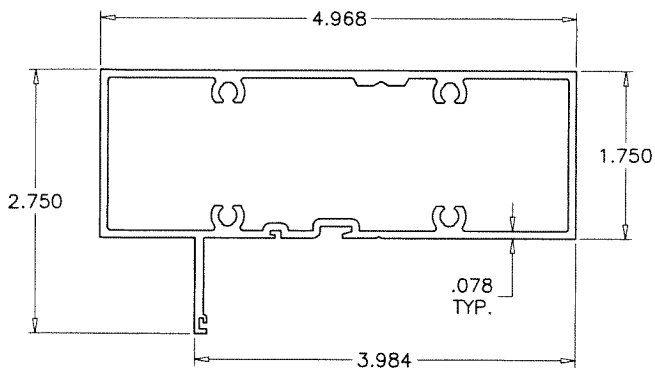

① HOLLOW FRAME HEAD/SILL

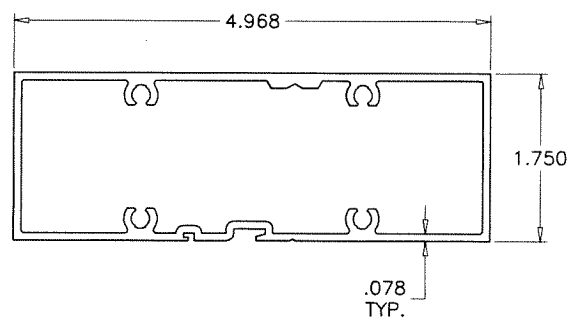

①.1

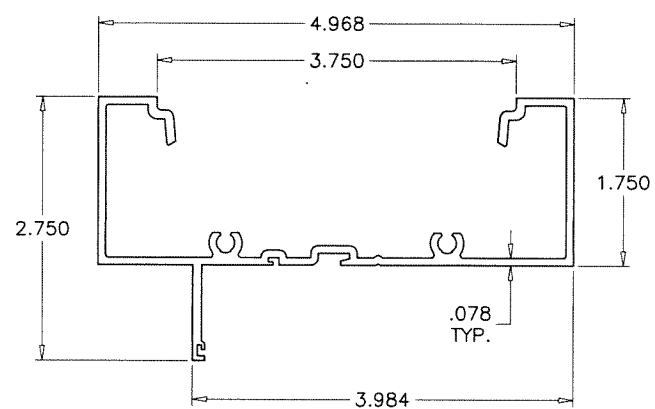

①A FRAME HEAD/SILL/JAMB/MULLION

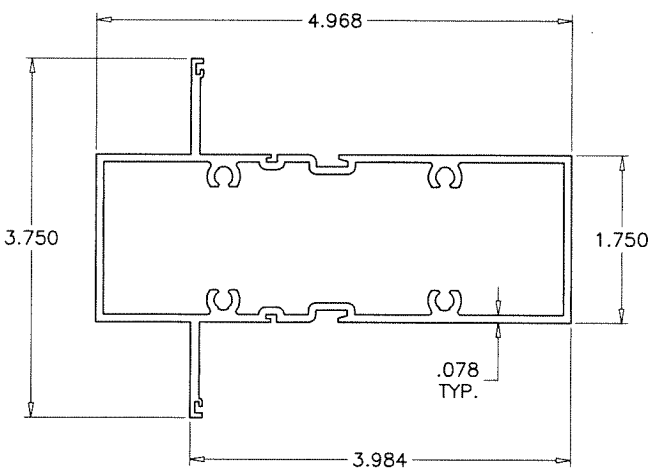

② INTERMEDIATE HORIZONTAL

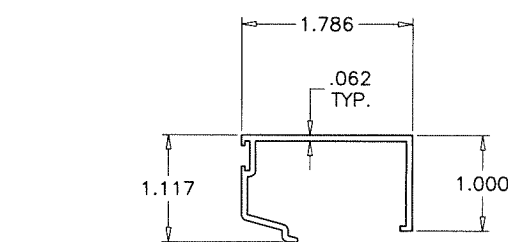

④ GLASS STOP

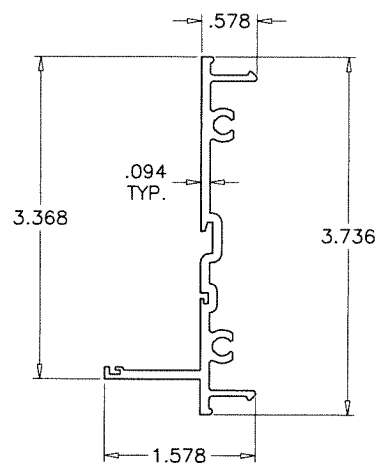

⑤ MULLION SNAP-IN MATE

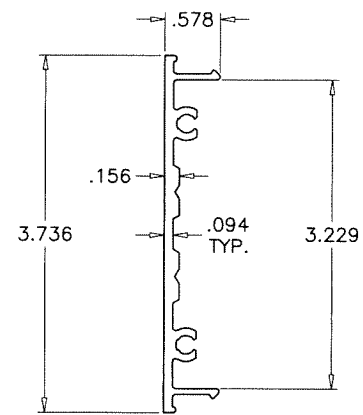

⑥ SHEAR CLIP

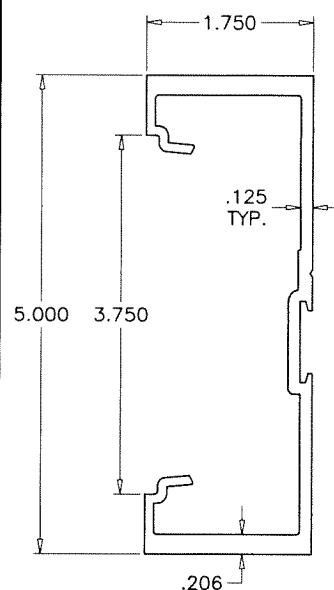

③A DOOR MULLION

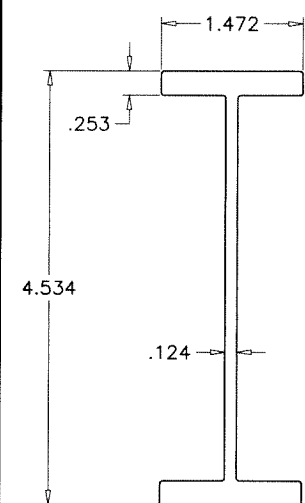

⑫ STIFFENER

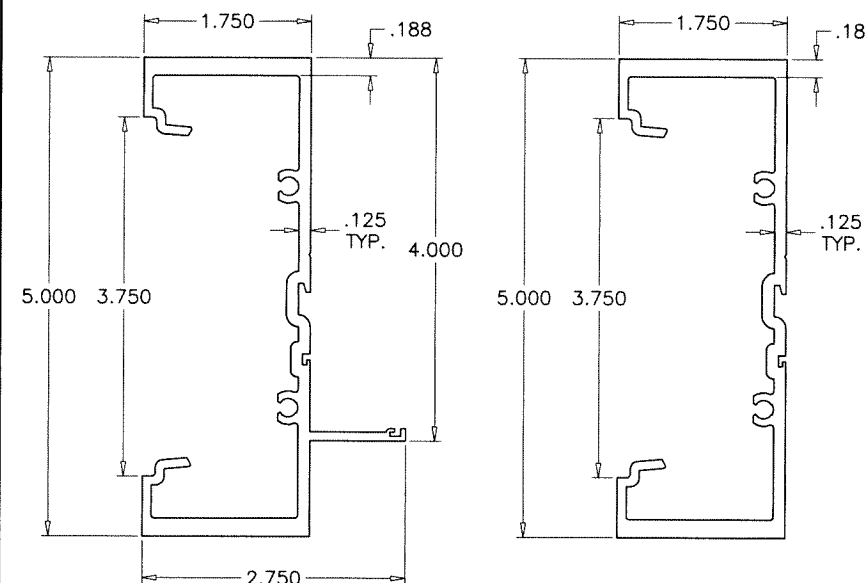

③ FRAME JAMB/MULLION

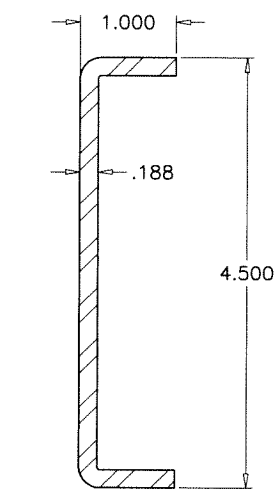

⑬ STEEL REINFORCING
36 KSI MIN.

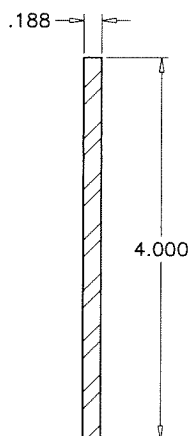

⑭

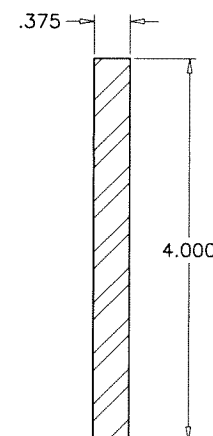

⑮

ITEM NO.	PART NUMBER	QUANTITY	DESCRIPTION	MATERIAL	MANF./SUPPLIER/REMARKS
1	ES8005	AS REQD.	HOLLOW FRAME HEAD/SILL	6005-T5	-
1A	ES8007	AS REQD.	FRAME HEAD/SILL/JAMB/MULLION	6063-T6	-
2	ES8004	AS REQD.	INTERMEDIATE HORIZONTAL	6063-T6	-
3	ES8001	AS REQD.	FRAME JAMB/MULLION	6005-T5	-
3A	ES8012	AS REQD.	DOOR MULLION	6005-T5	-
4	ES8006	AS REQD.	GLASS STOP	6063-T5	-
5	ES8002	AS REQD.	MULLION SNAP-IN MATE	6005-T5	-
6	ES8003	AS REQD.	SHEAR CLIP	6005-T5	-
7	-	AS REQD.	INTERIOR BULB GASKET	VINYL	-
8	ES8009	AS REQD.	SILICONE STOP	VINYL	-
8A	ES-8011A	AS REQD.	1/4" BUTTON BUMPER SPACER	SILICONE	DUROMETER 85±5 SHORE A
9	-	-	FRAME JAMB/MULLION	-	-
10	-	2/ LITE	3/16" X 1/2" X 2" LONG SETTING BLOCK, AT 1/4" POINTS	EPDM	DUROMETER 85±5 SHORE A
11	#12 X 1-1/2"	4/ CORNER	ASSEMBLY SCREWS PHSMS	STEEL	-
12	-	AS REQD.	MULLION STIFFENER	6005-T5	-
13	-	AS REQD.	MULLION REINFORCING CHANNEL	STEEL	-
14	-	AS REQD.	MULLION REINFORCING BAR (3/16" X 4")	STEEL	-
15	-	AS REQD.	MULLION REINFORCING BAR (3/8" X 4")	STEEL	-

af c
AL-FAROOQ CORPORATION
 ENGINEERS & PRODUCT DEVELOPMENT
 9360 SUNSET DRIVE, SUITE 220
 MIAMI, FLORIDA 33173 (C.A.N. 3538)
 TEL. (305) 264-8100 FAX. (305) 262-6978
 STORE 21-01F-SW

SERIES 8000 ALUM WINDOW WALL SYSTEM (L.M.I.)
Sunshine Windows Manufacturing, Inc.
 1785 West 33rd Place
 Hialeah, FL 33012
 Tel. (305) 364-9952 Fax. (305) 828-5118

revisions:	no	date	by	description
date:	01-07-21	scale:	1/2" = 1"	dr. by: TARIQ
chk. by:				
drawing no.	21-01F			
sheet	11 of 12			

Sealed: 7/26/2023

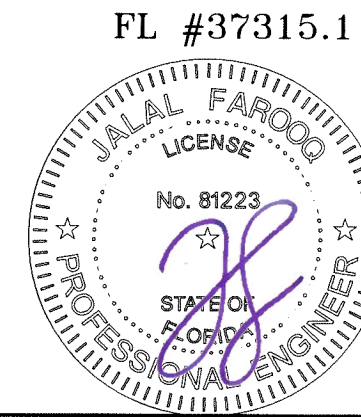

FL #37315.1

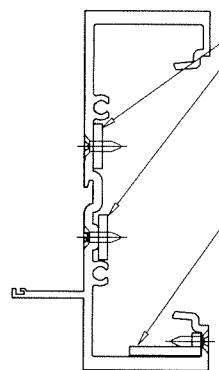
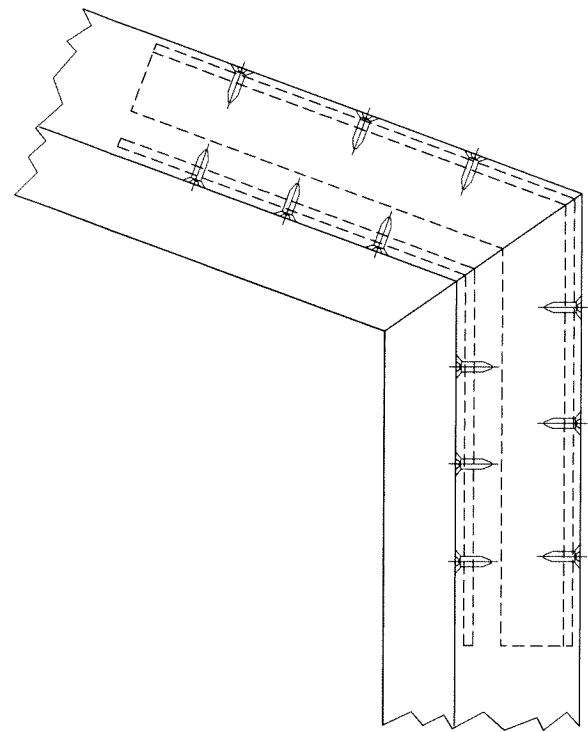

5/8" X 1/8"
ALUM PLATE
BENT TO MATCH JOINT
SECURED WITH #8 SMS
(3) PER SIDE OF JOINT

5/16 X 1 X 1/8"
ALUM ANGLE
BENT TO MATCH JOINT
SECURED WITH #8 SMS
(3) PER SIDE OF JOINT

CIRCULAR OR ANGLED CORNERS

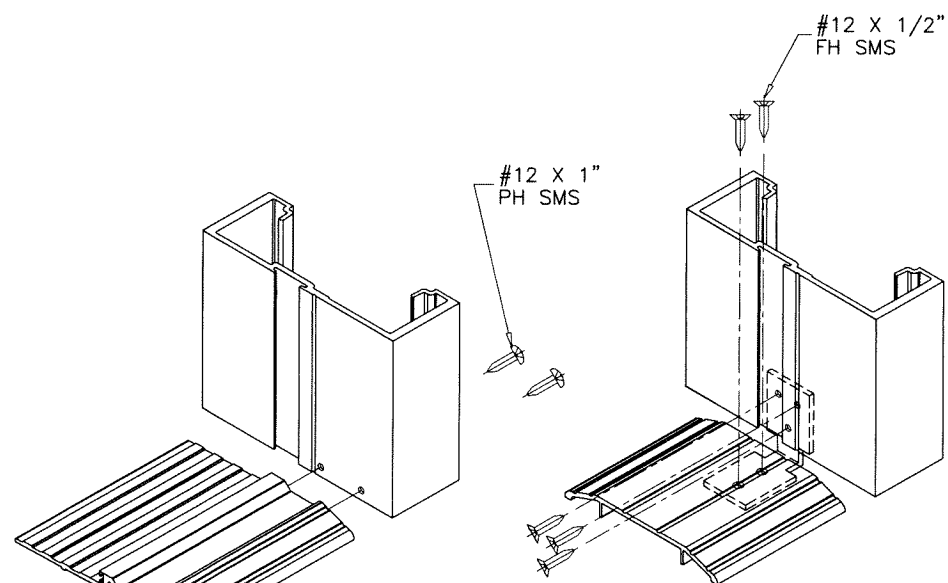

DOOR MULLION CORNER

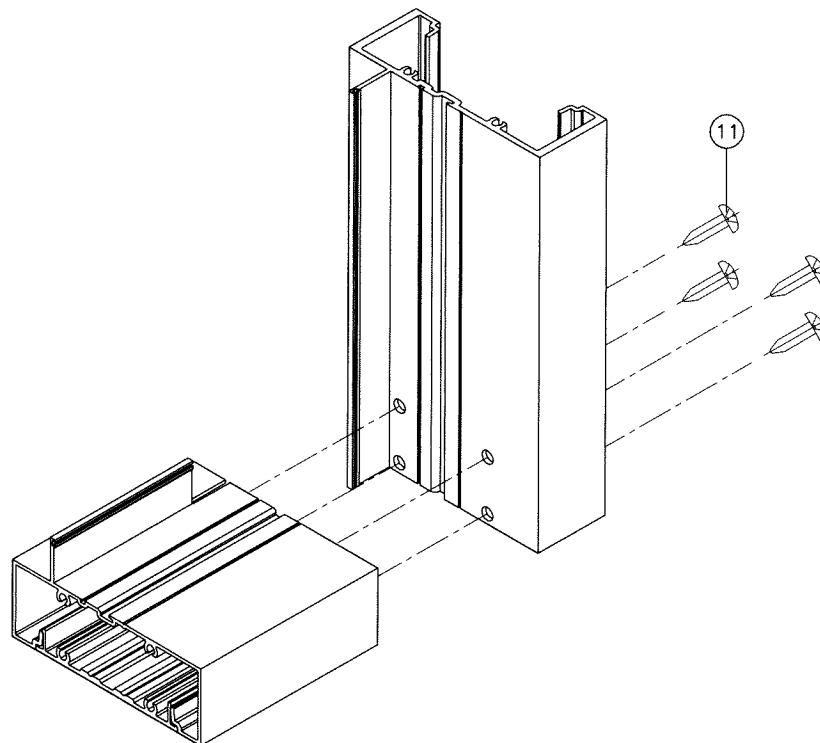
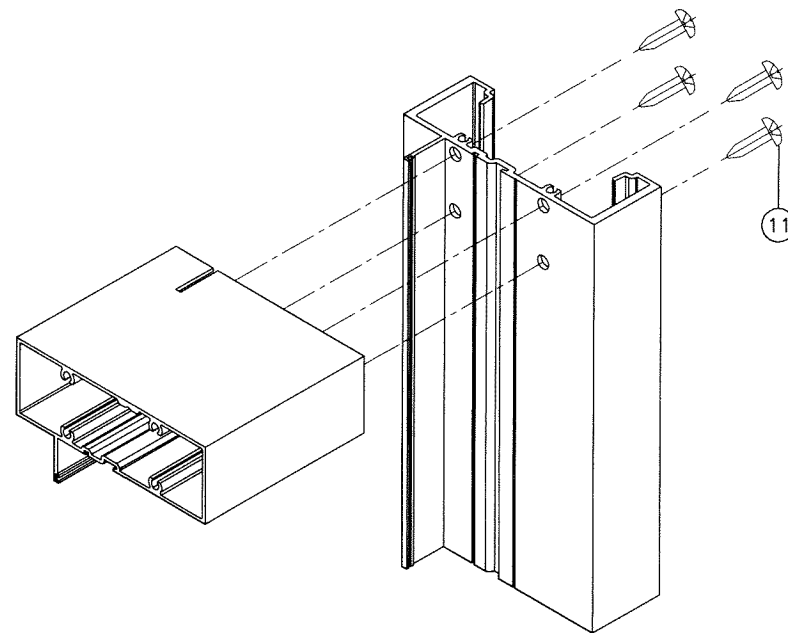

RECT. OR SQUARE CORNERS

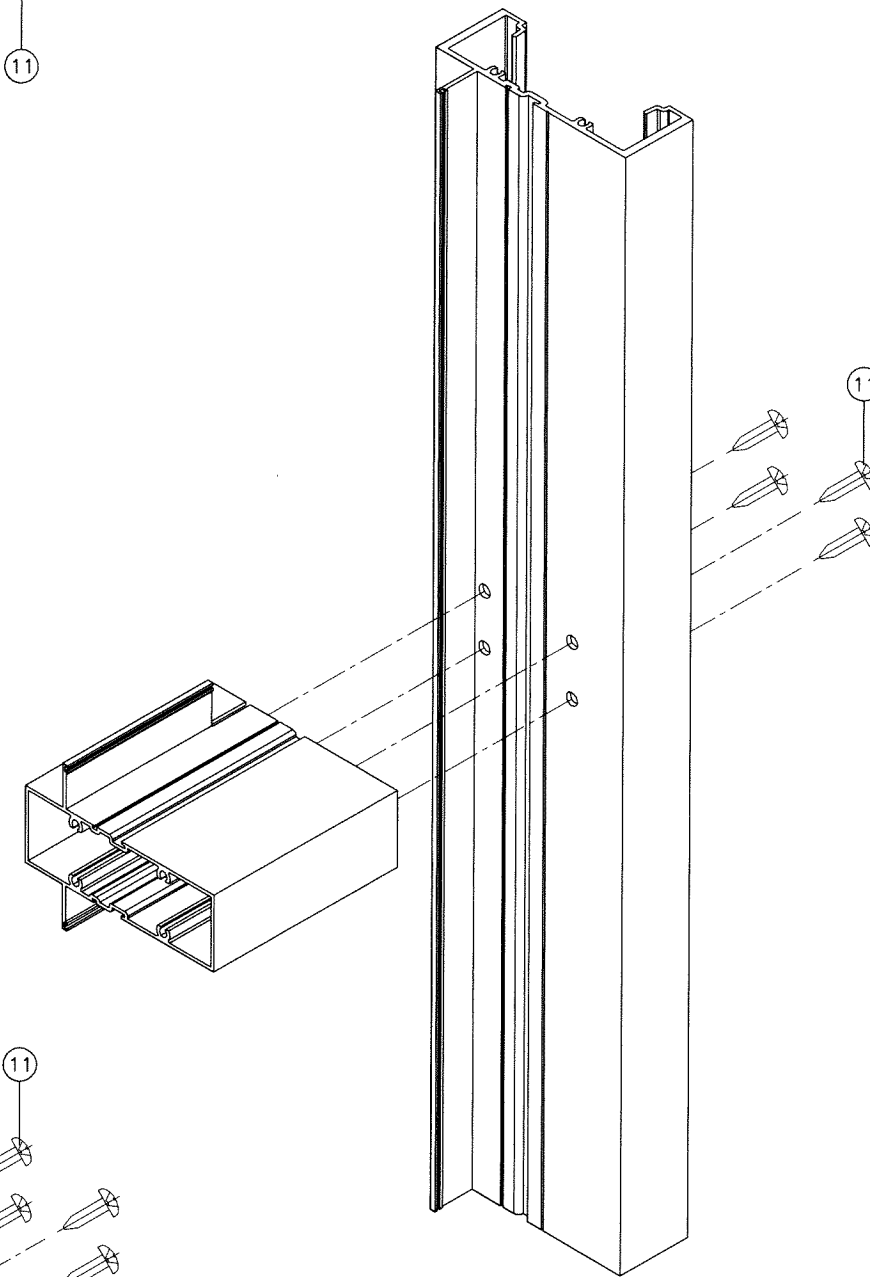

HORIZONTAL CORNER

Sealed: 7/26/2023

FL #37315.1

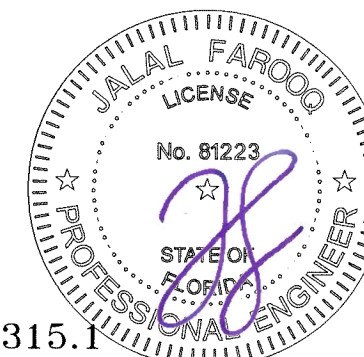

af c
AL-FAROOQ CORPORATION
ENGINEERS & PRODUCT DEVELOPMENT
9360 SUNSET DRIVE, SUITE 220
MIAMI, FLORIDA 33173 (C.A.N. 3538)
TEL. (305) 264-8100 FAX. (305) 262-6978
STORE 21-01F-SW

SERIES 8000 ALUM WINDOW WALL SYSTEM (L.M.I.)
Sunshine Windows Manufacturing, Inc.
1785 West 33rd Place
Hialeah, FL 33012
Tel. (305) 364-9952 Fax. (305) 828-5118

no	date	by	description

date: 01-07-21
scale: -
dr. by: TARIQ
chk. by:

drawing no.
21-01F
sheet 12 of 12